

Series LS04

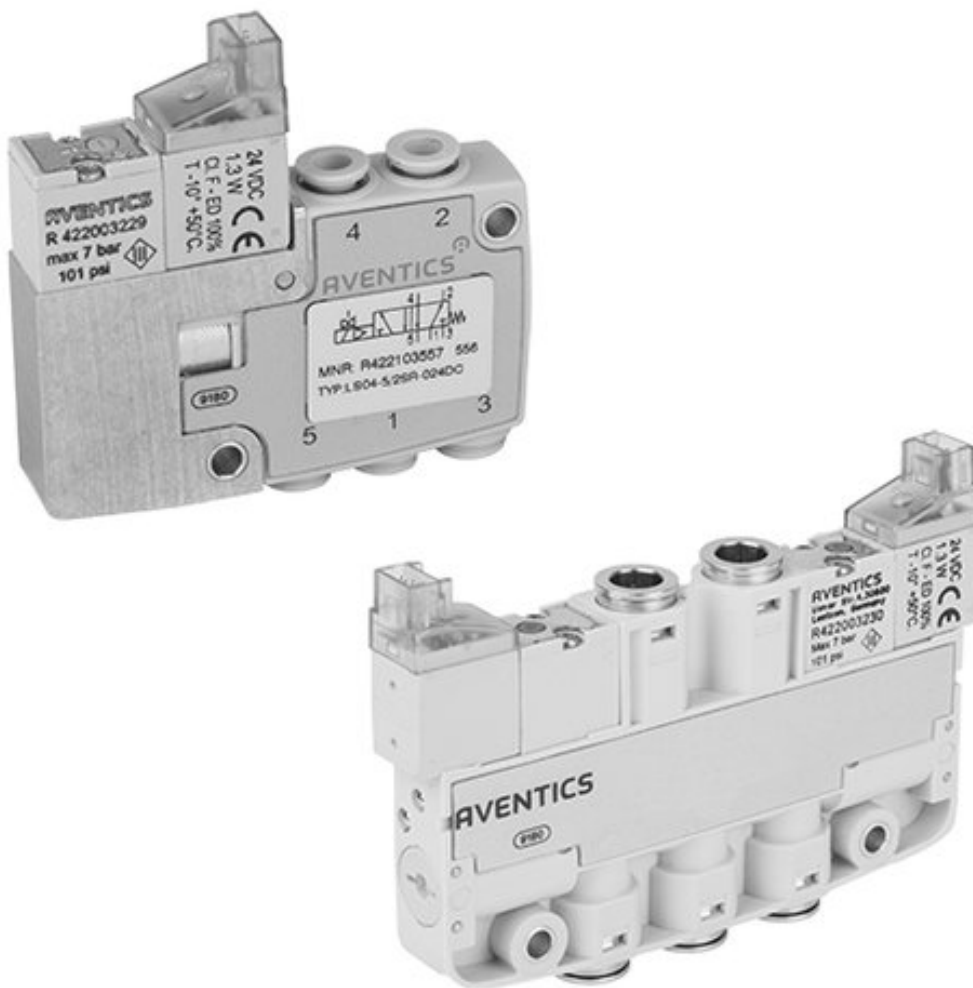

AVENTICS™ Series LS04

















3/2 directional valve, LS04-AF series

- 2x3/2
- Qn = 175-310 l/min
- NO/NO NC/NC NC/NO
- Pipe connection
- Compressed air connection output : Ø 4 Ø 6
- Electrical connection : Plug, M8, 3-pin
- Manual override : without detent
- Pilot : Internal



Type	Spool valve
Activation	Electrically
Pilot	Internal
Sealing principle	Soft sealing
Working pressure min./max.	See table below
Ambient temperature min./max.	-10 ... 50 °C
Medium temperature min./max.	-10 ... 50 °C
Medium	Compressed air
Max. particle size	5 µm
Oil content of compressed air	0 ... 5 mg/m ³
Nominal flow Qn	See table below
Connector standard	DIN EN 60947-5-2
Protection class acc. to DIN EN 61140 Electrically	Class III
Protection class with connection	IP65
Protective circuit	Z-diode
LED status display	Yellow
Duty cycle	100 %
Typ. switch-on time	12 ms
Typ. switch-off time	15 ms
Generic emission standard in accordance with	EN 61000-6-4:2002
Generic immunity standard in accordance with	IEC 61000-6-2:2005
mounting screws	M3
Mounting screw tightening torque	0,5 Nm
Weight	0,064 kg

Technical data

Part No.		MO		Compressed air connection	
				Input	
R422103573				NO/NO	Ø 4
R422103574				NO/NO	Ø 6
R422103581				NC/NC	Ø 4
R422103582				NC/NC	Ø 6
R422103602				NC/NC	Ø 6
R422103589				NC/NO	Ø 4
R422103590				NC/NO	Ø 6

Part No.	Compressed air connection		Compressed air connection	
	Output		Exhaust	
R422103573	Ø 4		Ø 4	
R422103574	Ø 6		Ø 6	
R422103581	Ø 4		Ø 4	
R422103582	Ø 6		Ø 6	
R422103602	Ø 6		Ø 6	
R422103589	Ø 4		Ø 4	
R422103590	Ø 6		Ø 6	

Part No.	Operational voltage	Voltage tolerance	Power consumption
	DC	DC	DC
R422103573	24 V	-10% / +10%	1,3 W
R422103574	24 V	-10% / +10%	1,3 W
R422103581	24 V	-10% / +10%	1,3 W
R422103582	24 V	-10% / +10%	1,3 W
R422103602	24 V	-10% / +10%	1,3 W
R422103589	24 V	-10% / +10%	1,3 W
R422103590	24 V	-10% / +10%	1,3 W

Part No.	Flow conductance	Flow conductance	Nominal flow Q _n	Working pressure min. / max.	
	b	C-value			
R422103573	0,4	0,8 l/(s*bar)	175 l/min	3 ... 7 bar	-
R422103574	0,25	1,2 l/(s*bar)	250 l/min	3 ... 7 bar	-
R422103581	0,4	0,8 l/(s*bar)	180 l/min	3 ... 7 bar	-
R422103582	0,3	1,5 l/(s*bar)	310 l/min	3 ... 7 bar	-
R422103602	0,3	1,5 l/(s*bar)	310 l/min	3,5 ... 7 bar	1)
R422103589	0,4	0,8 l/(s*bar)	175 l/min	3 ... 7 bar	-
R422103590	0,25	1,2 l/(s*bar)	250 l/min	3 ... 7 bar	-

Nominal flow Q_n at 6 bar and Δp = 1 bar, MO = Manual override

1) Due to its design, this 2x3/2 directional valve with negative overlap cannot remain in a position where all channels are closed.

Technical information

The min. control pressure must be adhered to, since otherwise faulty switching and valve failure may result!

The pressure dew point must be at least 15 °C under ambient and medium temperature and may not exceed 3 °C .

The oil content of compressed air must remain constant during the life cycle.

Use only the approved oils from AVENTICS. Further information can be found in the "Technical information" document (available in the MediaCentre).

A duty cycle of 100 percent is only valid for single valves.

Technical information

Material	
Housing	Polyoxymethylene
Seals	Acrylonitrile butadiene rubber Hydrogenated nitrile butadiene rubber Polyurethane

Dimensions

Dimensions, double solenoid

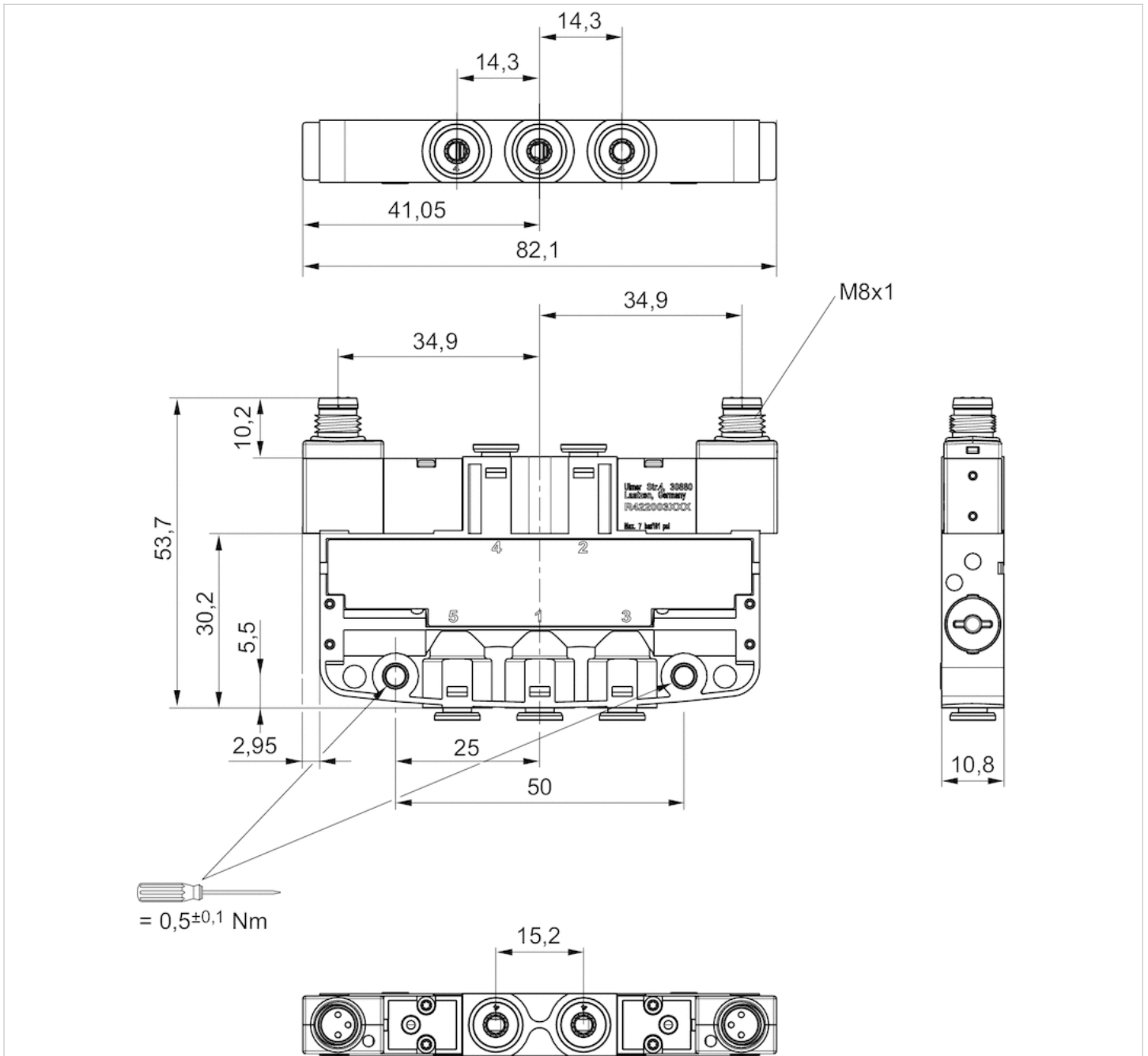

Pin assignments

PIN assignment for valve plug connectors, 3-pin

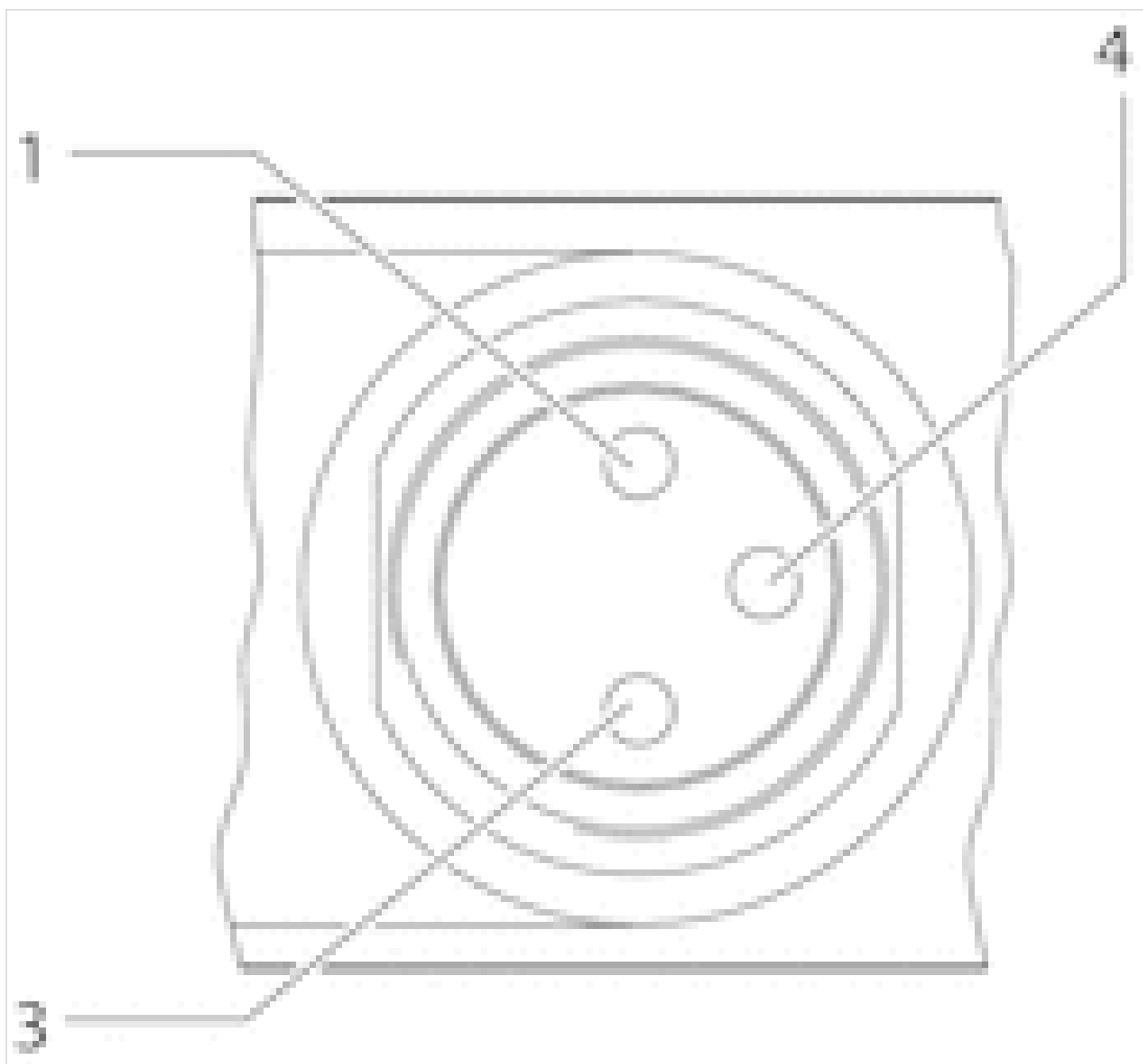

- 1) Pin not assigned
- 3) 0 V
- 4) 24 V

Note: Bi-polar protective circuit to prevent overvoltage













2x3/2-directional valve, Series LS04-AF

- 2x3/2
- Qn = 175-310 l/min
- NO/NO NC/NC NC/NO
- Pipe connection
- Compressed air connection output : Ø 4 Ø 6
- Electrical connection : Plug, M8, 3-pin
- Manual override : with detent
- Pilot : Internal



Version	Spool valve, positive overlapping
Activation	Electrically
Pilot	Internal
Sealing principle	Soft sealing
Working pressure min./max.	3 ... 7 bar
Ambient temperature min./max.	-10 ... 50 °C
Medium temperature min./max.	-10 ... 50 °C
Medium	Compressed air
Max. particle size	5 µm
Oil content of compressed air	0 ... 5 mg/m ³
Nominal flow Qn	See table below
Connector standard	DIN EN 60947-5-2
Protection class acc. to DIN EN 61140 Electrically	Class III
Protection class with connection	IP65
Protective circuit	Z-diode
LED status display	Yellow
Duty cycle	100 %
Typ. switch-on time	12 ms
Typ. switch-off time	15 ms
Generic emission standard in accordance with	EN 61000-6-4:2002
Generic immunity standard in accordance with	IEC 61000-6-2:2005
mounting screws	M3
Mounting screw tightening torque	0.5 Nm
Weight	0.064 kg

Technical data

Part No.		MO		Compressed air connection	
				Input	
R422103577			NO/NO	Ø 4	
R422103578			NO/NO	Ø 6	
R422103585			NC/NC	Ø 4	
R422103586			NC/NC	Ø 6	
R422103593			NC/NO	Ø 4	
R422103594			NC/NO	Ø 6	

Part No.	Compressed air connection		Compressed air connection	
	Output		Exhaust	
R422103577	Ø 4		Ø 4	
R422103578	Ø 6		Ø 6	
R422103585	Ø 4		Ø 4	
R422103586	Ø 6		Ø 6	
R422103593	Ø 4		Ø 4	
R422103594	Ø 6		Ø 6	

Part No.	Operational voltage	Voltage tolerance	Power consumption
	DC	DC	DC
R422103577	24 V	-10% / +10%	1.3 W
R422103578	24 V	-10% / +10%	1.3 W
R422103585	24 V	-10% / +10%	1.3 W
R422103586	24 V	-10% / +10%	1.3 W
R422103593	24 V	-10% / +10%	1.3 W
R422103594	24 V	-10% / +10%	1.3 W

Part No.	Flow conductance		Nominal flow Q _n
	b	C-value	
R422103577	0.4	0.8 l/(s*bar)	175 l/min
R422103578	0.25	1.2 l/(s*bar)	250 l/min
R422103585	0.4	0.8 l/(s*bar)	180 l/min
R422103586	0.3	1.5 l/(s*bar)	310 l/min
R422103593	0.4	0.8 l/(s*bar)	175 l/min
R422103594	0.25	1.2 l/(s*bar)	250 l/min

Nominal flow Q_n at 6 bar and Δp = 1 bar, MO = Manual override

Technical information

The min. control pressure must be adhered to, since otherwise faulty switching and valve failure may result!

The pressure dew point must be at least 15 °C under ambient and medium temperature and may not exceed 3 °C .

The oil content of compressed air must remain constant during the life cycle.

Use only the approved oils from AVENTICS. Further information can be found in the "Technical information" document (available in the MediaCentre).

A duty cycle of 100 percent is only valid for single valves.

Technical information

Material	
Housing	Polyoxymethylene
Seals	Acrylonitrile butadiene rubber Hydrogenated nitrile butadiene rubber Polyurethane

Dimensions

Dimensions, double solenoid

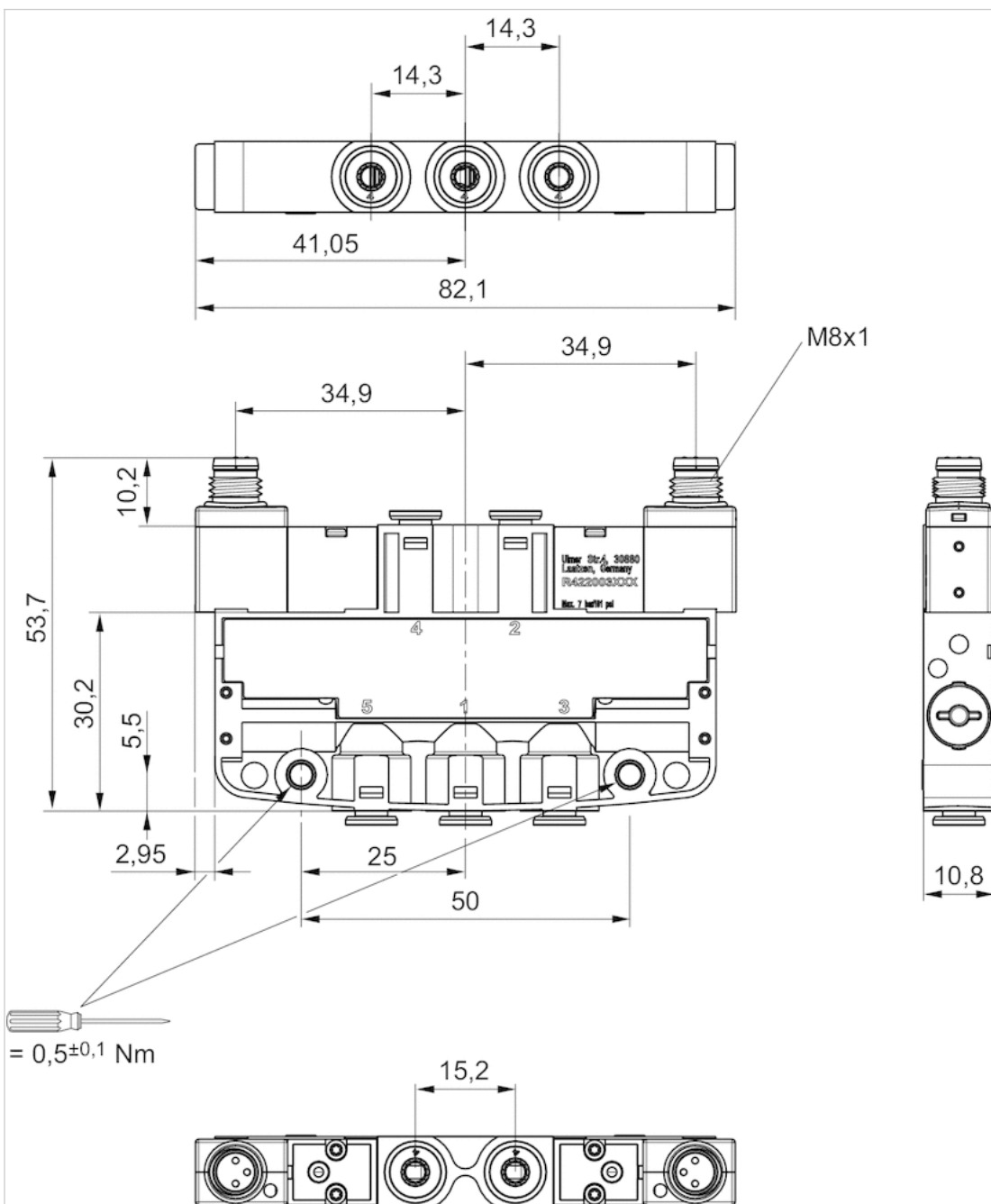

Pin assignments

PIN assignment for valve plug connectors

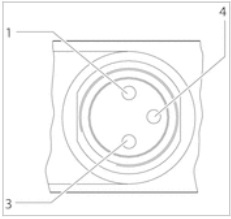

- 1) Pin not assigned
- 3) 0 V
- 4) 24 V

Note: Bi-polar protective circuit to prevent overvoltage













2x3/2-directional valve, Series LS04-AF

- 2x3/2
- Qn = 175-310 l/min
- NO/NO NC/NC NC/NO
- Pipe connection
- Compressed air connection output : Ø 4 Ø 6
- Electrical connection : 2, Plug, Industrial plug connector, 2-pin
- Manual override : without detent
- Pilot : Internal



Version	Spool valve, positive overlapping
Activation	Electrically
Pilot	Internal
Sealing principle	Soft sealing
Working pressure min./max.	3 ... 7 bar
Ambient temperature min./max.	-10 ... 50 °C
Medium temperature min./max.	-10 ... 50 °C
Medium	Compressed air
Max. particle size	5 µm
Oil content of compressed air	0 ... 5 mg/m ³
Nominal flow Qn	See table below
Protection class acc. to DIN EN 61140 Electrically	Class III
Protection class with connection	IP50
Protective circuit	Z-diode
LED status display	Yellow
Duty cycle	100 %
Typ. switch-on time	12 ms
Typ. switch-off time	15 ms
Generic emission standard in accordance with	EN 61000-6-4:2002
Generic immunity standard in accordance with	IEC 61000-6-2:2005
mounting screws	M3
Mounting screw tightening torque	0.5 Nm
Weight	0.064 kg

Technical data

Part No.		MO	Compressed air connection	
				Input
R422103571				Ø 4
R422103572			NO/NO	Ø 6
R422103579			NC/NC	Ø 4
R422103580			NC/NC	Ø 6
R422103587			NC/NO	Ø 4
R422103588			NC/NO	Ø 6

Part No.	Compressed air connection	
	Output	Exhaust
R422103571	Ø 4	Ø 4
R422103572	Ø 6	Ø 6
R422103579	Ø 4	Ø 4
R422103580	Ø 6	Ø 6
R422103587	Ø 4	Ø 4
R422103588	Ø 6	Ø 6

Part No.	Operational voltage	Voltage tolerance	Power consumption
	DC	DC	DC
R422103571	24 V	-10% / +10%	1.3 W
R422103572	24 V	-10% / +10%	1.3 W
R422103579	24 V	-10% / +10%	1.3 W
R422103580	24 V	-10% / +10%	1.3 W
R422103587	24 V	-10% / +10%	1.3 W
R422103588	24 V	-10% / +10%	1.3 W

Part No.	Flow conductance		Nominal flow Qn
	b	C-value	
R422103571	0.4	0.8 l/(s*bar)	175 l/min
R422103572	0.25	1.2 l/(s*bar)	250 l/min
R422103579	0.4	0.8 l/(s*bar)	180 l/min
R422103580	0.3	1.5 l/(s*bar)	310 l/min
R422103587	0.4	0.8 l/(s*bar)	175 l/min
R422103588	0.25	1.2 l/(s*bar)	250 l/min

Nominal flow Qn at 6 bar and $\Delta p = 1$ bar, MO = Manual override

Technical information

The min. control pressure must be adhered to, since otherwise faulty switching and valve failure may result!

The pressure dew point must be at least 15 °C under ambient and medium temperature and may not exceed 3 °C .

The oil content of compressed air must remain constant during the life cycle.

Use only the approved oils from AVENTICS. Further information can be found in the "Technical information" document (available in the MediaCentre).

A duty cycle of 100 percent is only valid for single valves.

Technical information

Material	
Housing	Polyoxymethylene
Seals	Acrylonitrile butadiene rubber Hydrogenated nitrile butadiene rubber Polyurethane

Dimensions

dimensions, double solenoid

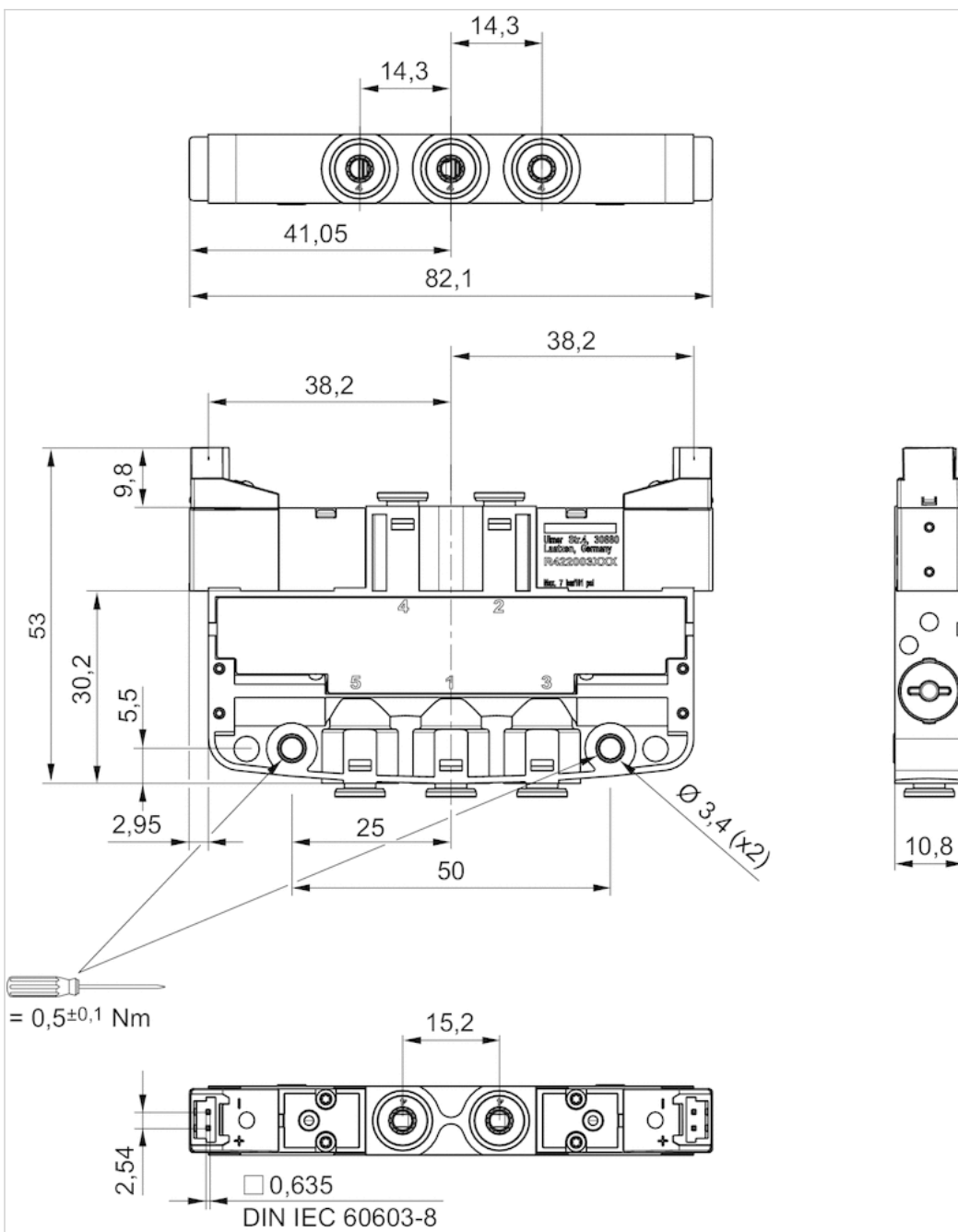













2x3/2-directional valve, Series LS04-AF

- 2x3/2
- Qn = 175-310 l/min
- NO/NO NC/NC NC/NO
- Pipe connection
- Compressed air connection output : Ø 4 Ø 6
- Electrical connection : 2, Plug, Industrial plug connector, 2-pin
- Manual override : with detent
- Pilot : Internal



Version	Spool valve, positive overlapping
Activation	Electrically
Pilot	Internal
Sealing principle	Soft sealing
Working pressure min./max.	3 ... 7 bar
Ambient temperature min./max.	-10 ... 50 °C
Medium temperature min./max.	-10 ... 50 °C
Medium	Compressed air
Max. particle size	5 µm
Oil content of compressed air	0 ... 5 mg/m ³
Nominal flow Qn	See table below
Protection class acc. to DIN EN 61140 Electrically	Class III
Protection class with connection	IP50
Protective circuit	Z-diode
LED status display	Yellow
Duty cycle	100 %
Typ. switch-on time	12 ms
Typ. switch-off time	15 ms
Generic emission standard in accordance with	EN 61000-6-4:2002
Generic immunity standard in accordance with	IEC 61000-6-2:2005
mounting screws	M3
Mounting screw tightening torque	0.5 Nm
Weight	0.064 kg

Technical data

Part No.		MO		Compressed air connection	
				Input	
R422103575			NO/NO	Ø 4	
R422103576			NO/NO	Ø 6	
R422103583			NC/NC	Ø 4	
R422103584			NC/NC	Ø 6	
R422103591			NC/NO	Ø 4	
R422103592			NC/NO	Ø 6	

Part No.	Compressed air connection		Compressed air connection	
	Output		Exhaust	
R422103575	Ø 4		Ø 4	
R422103576	Ø 6		Ø 6	
R422103583	Ø 4		Ø 4	
R422103584	Ø 6		Ø 6	
R422103591	Ø 4		Ø 4	
R422103592	Ø 6		Ø 6	

Part No.	Operational voltage		Voltage tolerance		Power consumption	
	DC		DC		DC	
R422103575	24 V		-10% / +10%		1.3 W	
R422103576	24 V		-10% / +10%		1.3 W	
R422103583	24 V		-10% / +10%		1.3 W	
R422103584	24 V		-10% / +10%		1.3 W	
R422103591	24 V		-10% / +10%		1.3 W	
R422103592	24 V		-10% / +10%		1.3 W	

Part No.	Flow conductance		Flow conductance		Nominal flow Q _n
	b		C-value		
R422103575	0.4		0.8 l/(s*bar)		175 l/min
R422103576	0.25		1.2 l/(s*bar)		250 l/min
R422103583	0.4		0.8 l/(s*bar)		180 l/min
R422103584	0.3		1.5 l/(s*bar)		310 l/min
R422103591	0.4		0.8 l/(s*bar)		175 l/min
R422103592	0.25		1.2 l/(s*bar)		250 l/min

Nominal flow Q_n at 6 bar and Δp = 1 bar, MO = Manual override

Technical information

The min. control pressure must be adhered to, since otherwise faulty switching and valve failure may result!

The pressure dew point must be at least 15 °C under ambient and medium temperature and may not exceed 3 °C .

The oil content of compressed air must remain constant during the life cycle.

Use only the approved oils from AVENTICS. Further information can be found in the "Technical information" document (available in the MediaCentre).

A duty cycle of 100 percent is only valid for single valves.

Technical information

Material	
Housing	Polyoxymethylene
Seals	Acrylonitrile butadiene rubber Hydrogenated nitrile butadiene rubber Polyurethane

Dimensions

dimensions, double solenoid

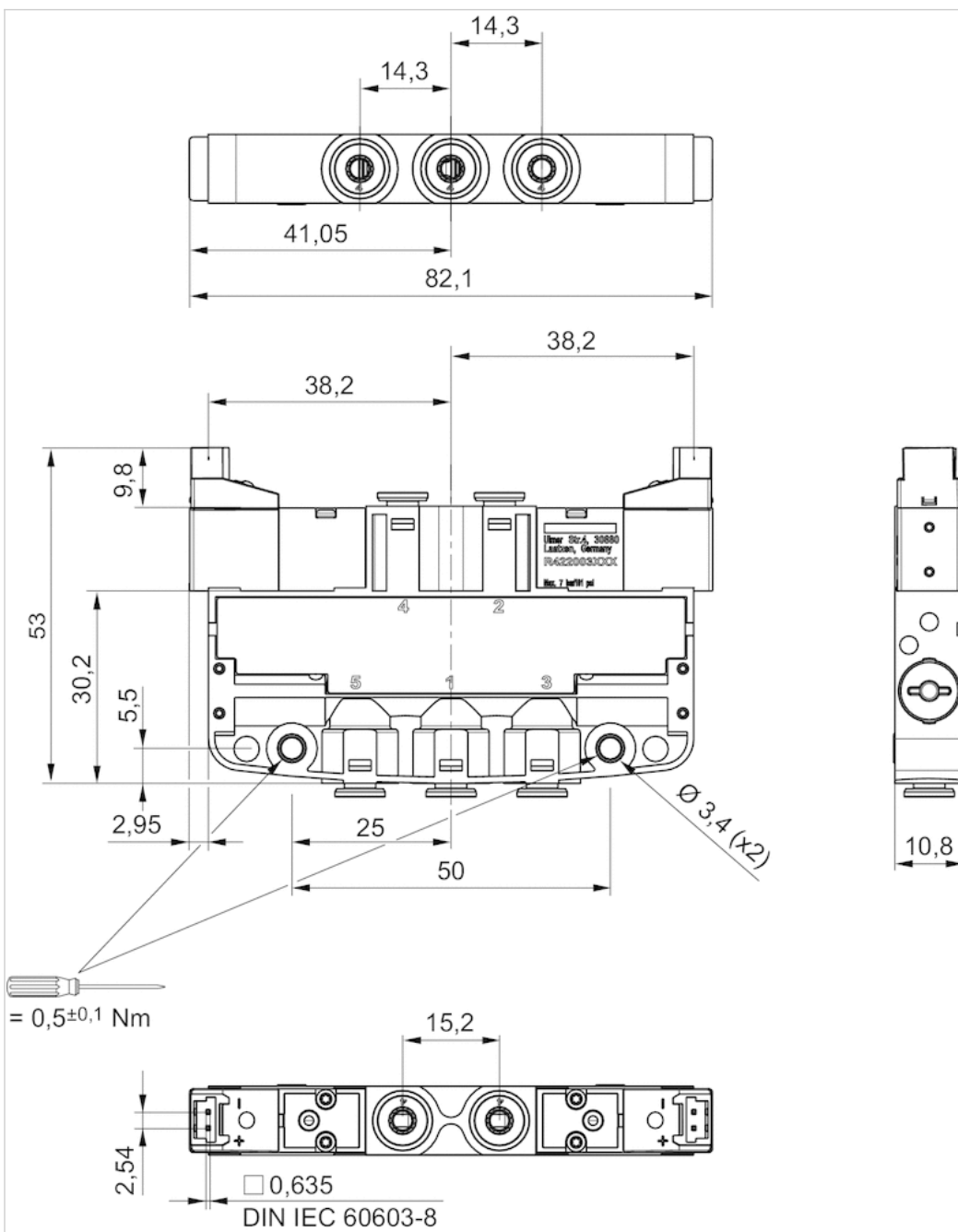

3/2-directional valve, Series LS04-PD

- with position detectio
- 3/
- Qn = 180-310 l/mi
- N
- Pipe connectio
- Compressed air connection output : $\varnothing 4 \varnothing$
- Electrical connection : M8, 3-pi
- Manual override : without deten
- Pilot : Interna

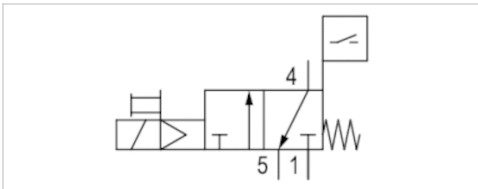

Type	Spool valve
Activation	Electrically
Pilot	Internal
Sealing principle	Soft sealing
Working pressure min./max.	3 ... 7 bar
Ambient temperature min./max.	-10 ... 50 °C
Medium temperature min./max.	-10 ... 50 °C
Medium	Compressed air
Max. particle size	5 μm
Oil content of compressed air	0 ... 5 mg/m ³
Nominal flow Qn	See table below
Connector standard	DIN EN 60947-5-2
Protection class acc. to DIN EN 61140	Class III
Electrically	
Protection class with connection	IP65
Protective circuit	Z-diode
LED status display	Yellow
Typ. switch-on time	12 ms
Typ. switch-off time	30 ms
Generic emission standard in accordance with	EN 61000-6-4:2002
Generic immunity standard in accordance with	IEC 61000-6-2:2005
Type sensor	electronic PNP, with LED
Sensor Electrical interface	M8
Operating voltage sensor DC min./max.	10 ... 30 V DC
Voltage drop sensor U at I _{max}	≤ 2,0 V
mounting screws	M3
Mounting screw tightening torque	0,5 Nm
Weight	0,053 kg

Technical data

Part No.		Compressed air connection	
		Input	Output
R422005154	NC	Ø 4	Ø 4
R422004129	NC	Ø 6	Ø 6

Part No.	Compressed air connection		Operational voltage	Voltage tolerance
	Exhaust			
R422005154	Ø 4		DC 24 V	DC -10% / +10%
R422004129	Ø 6		DC 24 V	DC -10% / +10%

Part No.	Power consumption	Flow conductance	Flow conductance	Nominal flow Qn
	DC	b	C-value	
R422005154	1,3 W	0,4	0,8 l/(s*bar)	180 l/min
R422004129	1,3 W	0,25	1,5 l/(s*bar)	310 l/min

Nominal flow Qn at 6 bar and $\Delta p = 1$ bar, MO = Manual override

Technical information

The min. control pressure must be adhered to, since otherwise faulty switching and valve failure may result!

The pressure dew point must be at least 15 °C under ambient and medium temperature and may not exceed 3 °C .

The oil content of compressed air must remain constant during the life cycle.

Use only the approved oils from AVENTICS. Further information can be found in the "Technical information" document (available in the MediaCentre).

A duty cycle of 100% is only valid for valves mounted separately.

If the solenoid valve is switched off, the flow direction is from connection 4 to 5. The sensor output signal is high and the red LED is illuminated. The maximum sensor current is 12 mA.

Technical information

Material	
Housing	Polyoxymethylene
Seals	Acrylonitrile butadiene rubber Hydrogenated nitrile butadiene rubber Polyurethane

Dimensions

Dimensions

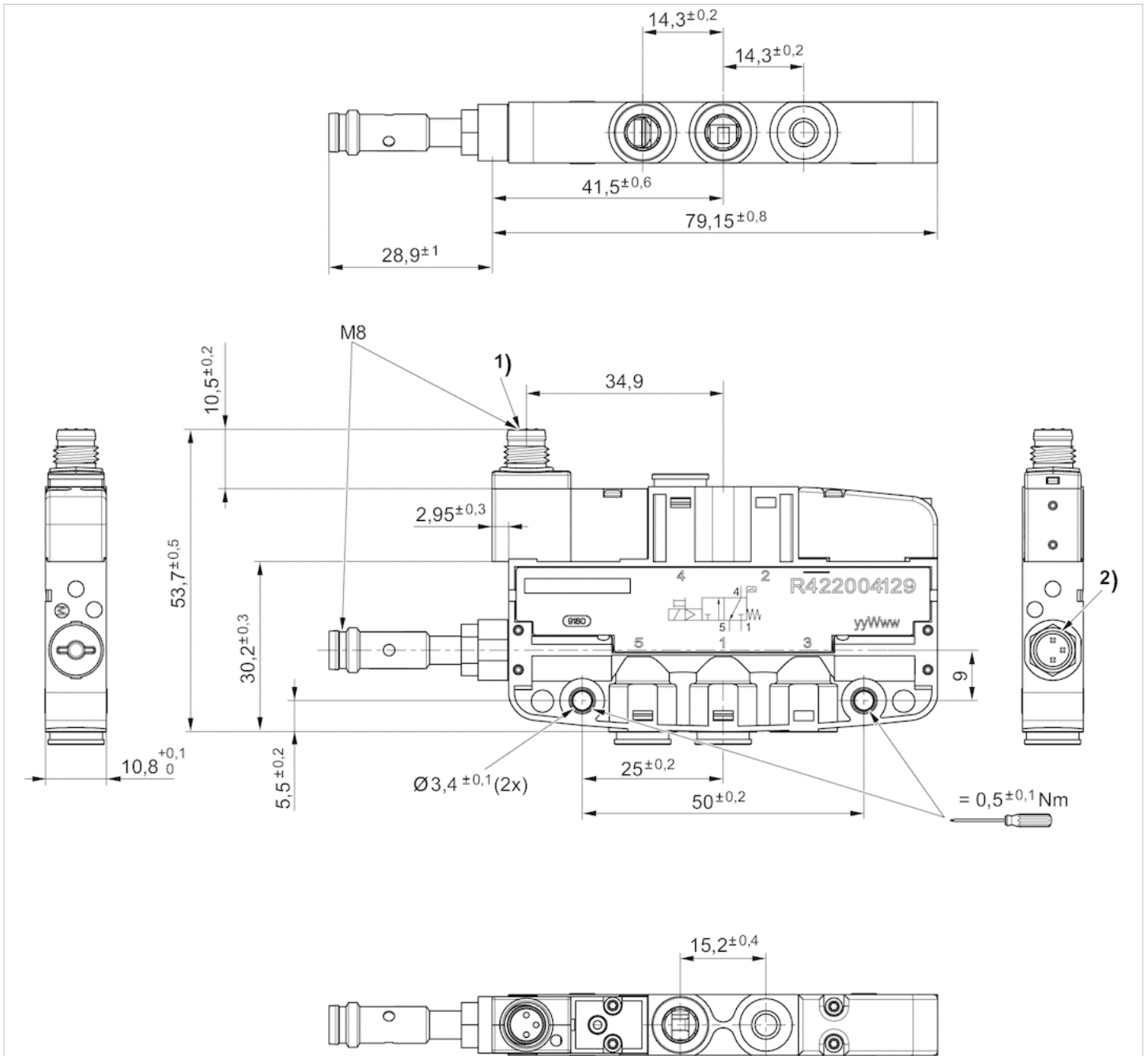

- 1) Valve plug connector M8
- 2) Sensor plug M8, 3-pin

Pin assignments

PIN assignment for valve plug connectors, 3-pin

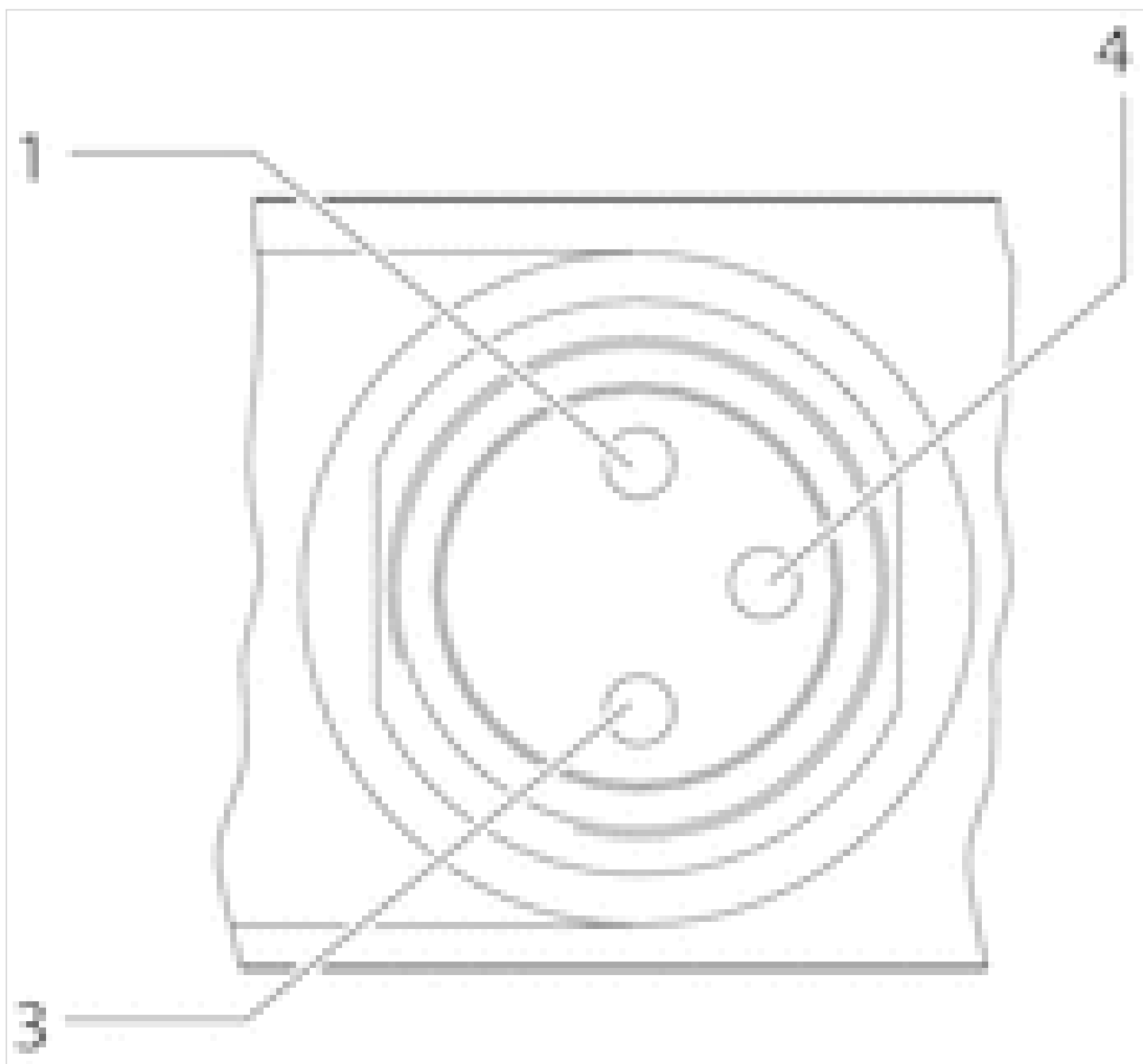

- 1) Pin not assigned
- 3) 0 V
- 4) 24 V

Note: Bi-polar protective circuit to prevent overvoltage

PIN assignment sensor, plug M8, 3-pin

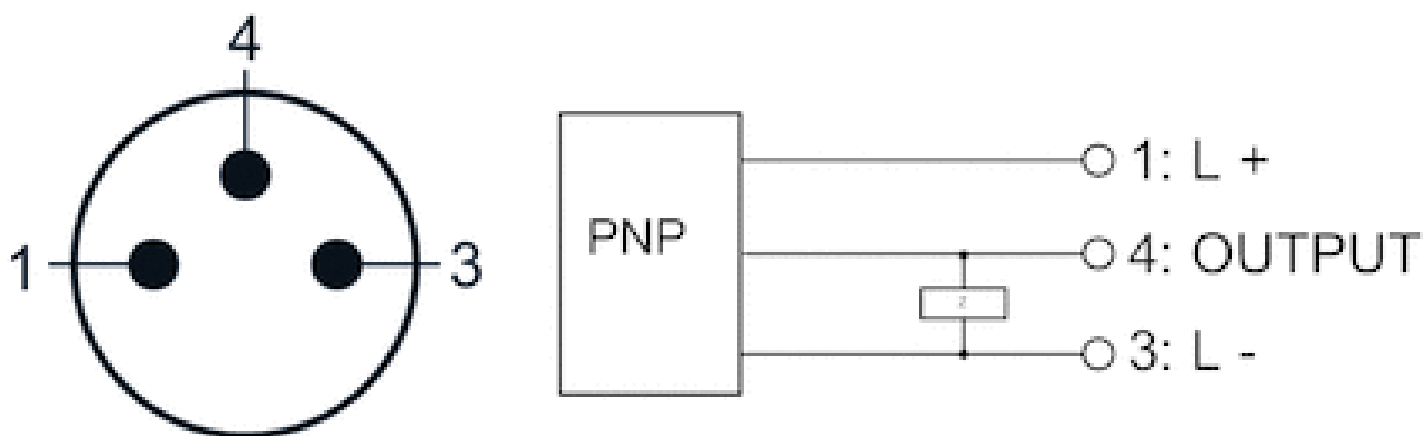









5/2-directional valve, Series LS04-AF

- 5/2
- Qn = 180-310 l/min
- Pipe connection
- Compressed air connection output : Ø 4 Ø 6
- Electrical connection : Plug, M8, 3-pin
- Manual override : without detent
- single solenoid double solenoid
- With spring return
- Pilot : Internal



Version	Spool valve, positive overlapping
Activation	Electrically
Pilot	Internal
Sealing principle	Soft sealing
Working pressure min./max.	See table below
Ambient temperature min./max.	-10 ... 50 °C
Medium temperature min./max.	-10 ... 50 °C
Medium	Compressed air
Max. particle size	5 µm
Oil content of compressed air	0 ... 5 mg/m ³
Nominal flow Qn	See table below
Connector standard	DIN EN 60947-5-2
Protection class acc. to DIN EN 61140 Electrically	Class III
Protection class with connection	IP65
Protective circuit	Z-diode
LED status display	Yellow
Duty cycle	100 %
Generic emission standard in accordance with	EN 61000-6-4:2002
Generic immunity standard in accordance with	IEC 61000-6-2:2005
mounting screws	M3
Mounting screw tightening torque	0.5 Nm
Weight	See table below
Comment	The delivered product may vary from that in the illustration.

Technical data

Part No.		MO	Compressed air connection	
			Input	Output
R422103561			Ø 4	Ø 4
R422103562			Ø 6	Ø 6
R422103569			Ø 4	Ø 4
R422103570			Ø 6	Ø 6

Part No.	Compressed air connection		Operational voltage	Voltage tolerance
	Exhaust		DC	DC
R422103561	Ø 4		24 V	-10% / +10%
R422103562	Ø 6		24 V	-10% / +10%
R422103569	Ø 4		24 V	-10% / +10%
R422103570	Ø 6		24 V	-10% / +10%

Part No.	Power consumption	Flow conductance	Flow conductance	Nominal flow Qn
	DC	b	C-value	
R422103561	1.3 W	0.3	0.8 l/(s*bar)	180 l/min
R422103562	1.3 W	0.27	1.5 l/(s*bar)	310 l/min
R422103569	1.3 W	0.3	0.8 l/(s*bar)	180 l/min
R422103570	1.3 W	0.27	1.5 l/(s*bar)	310 l/min

Part No.	Working pressure min./max.	Typ. switch-on time	Typ. switch-off time	Weight
R422103561	3 ... 7 bar	10 ms	22 ms	0.053 kg
R422103562	3 ... 7 bar	10 ms	22 ms	0.053 kg
R422103569	2 ... 7 bar	9 ms	9 ms	0.063 kg
R422103570	2 ... 7 bar	9 ms	9 ms	0.063 kg

Nominal flow Qn at 6 bar and $\Delta p = 1$ bar, MO = Manual override

Technical information

The min. control pressure must be adhered to, since otherwise faulty switching and valve failure may result!

The pressure dew point must be at least 15 °C under ambient and medium temperature and may not exceed 3 °C .

The oil content of compressed air must remain constant during the life cycle.

Use only the approved oils from AVENTICS. Further information can be found in the "Technical information" document (available in the MediaCentre).

A duty cycle of 100 percent is only valid for single valves.

Technical information

Material	
Housing	Polyoxymethylene
Seals	Acrylonitrile butadiene rubber Hydrogenated nitrile butadiene rubber Polyurethane

Dimensions

Dimensions, double solenoid

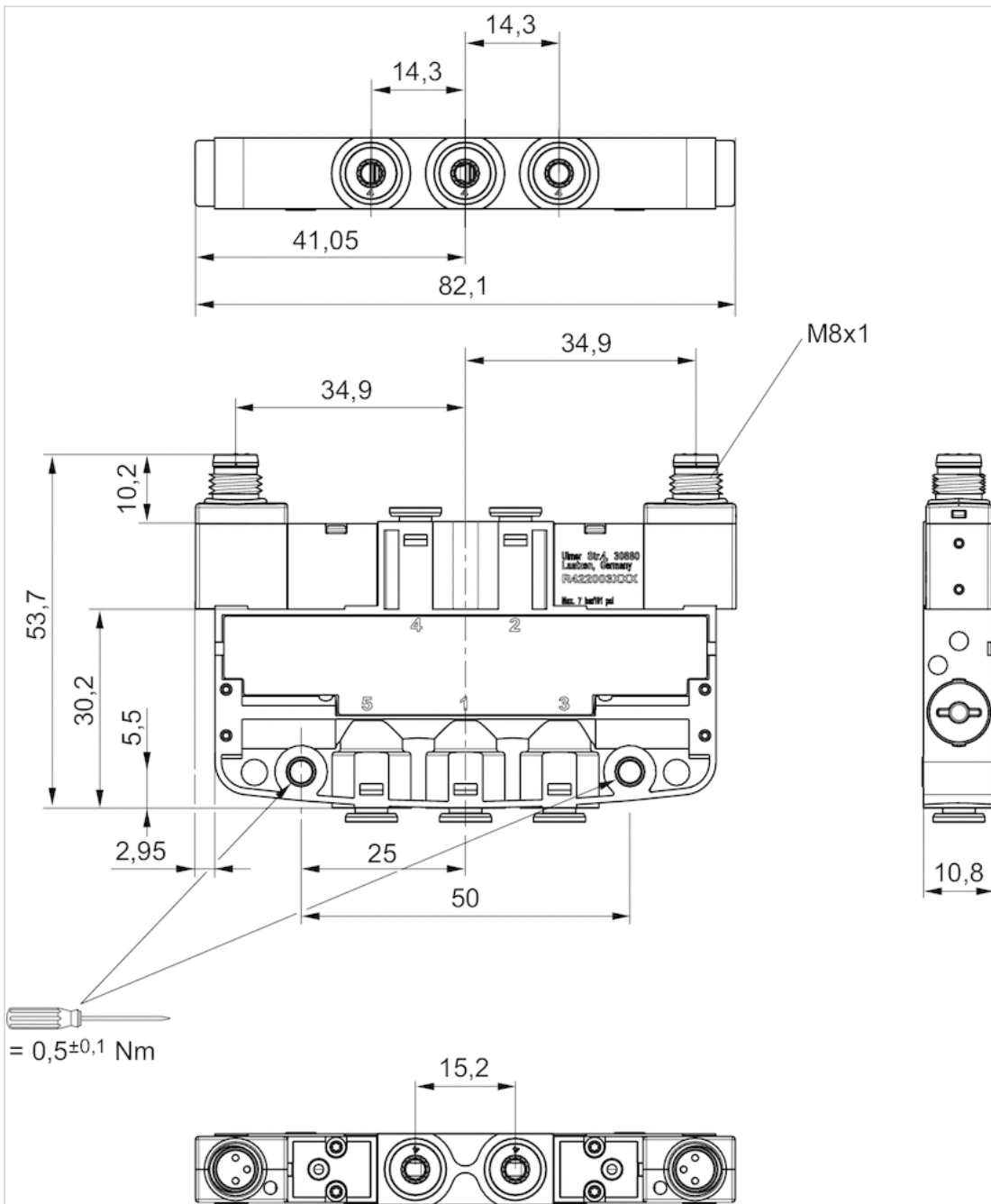

dimensions, single solenoid

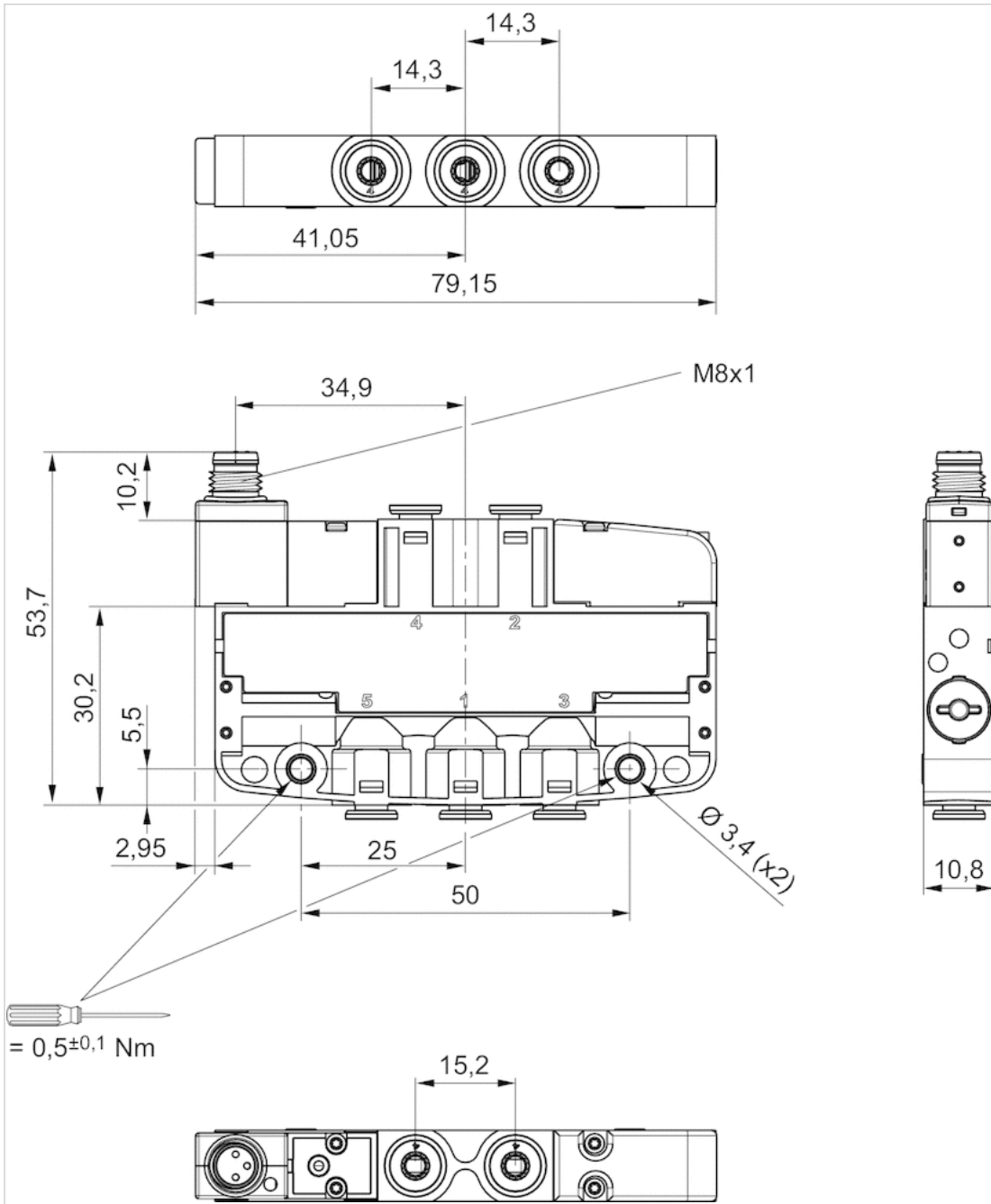

Pin assignments

PIN assignment for valve plug connectors

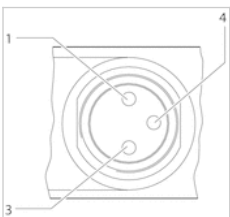

- 1) Pin not assigned
- 3) 0 V
- 4) 24 V

Note: Bi-polar protective circuit to prevent overvoltage

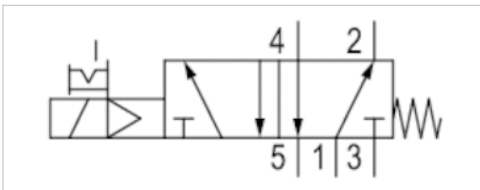

5/2-directional valve, Series LS04-AF

- 5/2
- $Q_n = 180-310$ l/min
- Pipe connection
- Compressed air connection output : $\varnothing 4 \varnothing 6$
- Electrical connection : Plug, M8, 3-pin
- Manual override : with detent
- single solenoid
- With spring return
- Pilot : Internal



Version	Spool valve, positive overlapping
Activation	Electrically
Pilot	Internal
Sealing principle	Soft sealing
Working pressure min./max.	3 ... 7 bar
Ambient temperature min./max.	-10 ... 50 °C
Medium temperature min./max.	-10 ... 50 °C
Medium	Compressed air
Max. particle size	5 μ m
Oil content of compressed air	0 ... 5 mg/m ³
Nominal flow Q_n	See table below
Connector standard	DIN EN 60947-5-2
Protection class acc. to DIN EN 61140	Class III
Electrically	
Protection class with connection	IP65
Protective circuit	Z-diode
LED status display	Yellow
Duty cycle	100 %
Typ. switch-on time	10 ms
Typ. switch-off time	22 ms
Generic emission standard in accordance with	EN 61000-6-4:2002
Generic immunity standard in accordance with	IEC 61000-6-2:2005
mounting screws	M3
Mounting screw tightening torque	0.5 Nm
Weight	0.053 kg

Technical data

Part No.	MO	Compressed air connection	
		Input	Output
R422103565		Ø 4	Ø 4
R422103566		Ø 6	Ø 6

Part No.	Compressed air connection		Operational voltage	Voltage tolerance
	Exhaust			
R422103565	Ø 4		DC 24 V	DC -10% / +10%
R422103566	Ø 6		DC 24 V	DC -10% / +10%

Part No.	Power consumption	Flow conductance	Flow conductance	Nominal flow Qn
	DC	b	C-value	
R422103565	1.3 W	0.3	0.8 l/(s*bar)	180 l/min
R422103566	1.3 W	0.27	1.5 l/(s*bar)	310 l/min

Nominal flow Qn at 6 bar and $\Delta p = 1$ bar, MO = Manual override

Technical information

The min. control pressure must be adhered to, since otherwise faulty switching and valve failure may result!

The pressure dew point must be at least 15 °C under ambient and medium temperature and may not exceed 3 °C .

The oil content of compressed air must remain constant during the life cycle.

Use only the approved oils from AVENTICS. Further information can be found in the "Technical information" document (available in the MediaCentre).

A duty cycle of 100 percent is only valid for single valves.

Technical information

Material	
Housing	Polyoxymethylene
Seals	Acrylonitrile butadiene rubber Hydrogenated nitrile butadiene rubber Polyurethane

Dimensions

dimensions, single solenoid

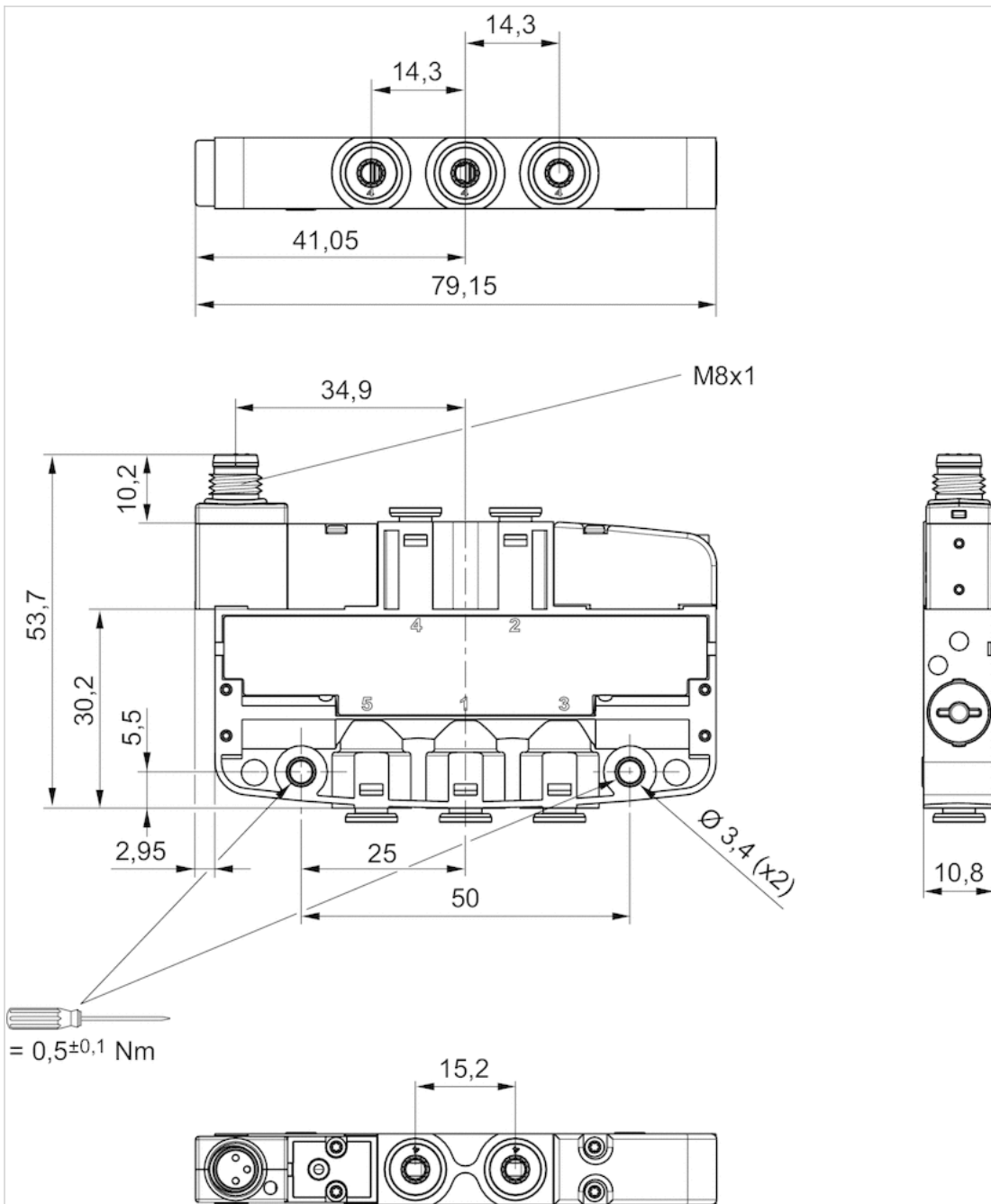

Pin assignments

PIN assignment for valve plug connectors

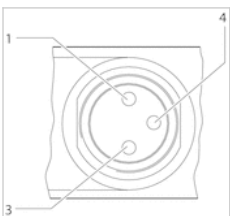

- 1) Pin not assigned
- 3) 0 V

4) 24 V

Note: Bi-polar protective circuit to prevent overvoltage









5/2-directional valve, Series LS04-AF

- 5/2
- Qn = 180-310 l/min
- Pipe connection
- Compressed air connection output : Ø 4 Ø 6
- Electrical connection : Plug, Industrial plug connector, 2-pin
- Manual override : without detent
- single solenoid double solenoid
- With spring return
- Pilot : Internal



Version	Spool valve, positive overlapping
Activation	Electrically
Pilot	Internal
Sealing principle	Soft sealing
Working pressure min./max.	See table below
Ambient temperature min./max.	-10 ... 50 °C
Medium temperature min./max.	-10 ... 50 °C
Medium	Compressed air
Max. particle size	5 µm
Oil content of compressed air	0 ... 5 mg/m ³
Nominal flow Qn	See table below
Protection class acc. to DIN EN 61140 Electrically	Class III
Protection class with connection	IP50
Protective circuit	Z-diode
LED status display	Yellow
Duty cycle	100 %
Generic emission standard in accordance with	EN 61000-6-4:2002
Generic immunity standard in accordance with	IEC 61000-6-2:2005
mounting screws	M3
Mounting screw tightening torque	0.5 Nm
Weight	See table below
Comment	The delivered product may vary from that in the illustration.

Technical data

Part No.		MO	Compressed air connection	
			Input	Output
R422103559			Ø 4	Ø 4
R422103560			Ø 6	Ø 6
R422103567			Ø 4	Ø 4
R422103568			Ø 6	Ø 6

Part No.	Compressed air connection		Operational voltage	Voltage tolerance
	Exhaust		DC	DC
R422103559	Ø 4		24 V	-10% / +10%
R422103560	Ø 6		24 V	-10% / +10%
R422103567	Ø 4		24 V	-10% / +10%
R422103568	Ø 6		24 V	-10% / +10%

Part No.	Power consumption	Flow conductance	Flow conductance	Nominal flow Qn
	DC	b	C-value	
R422103559	1.3 W	0.3	0.8 l/(s*bar)	180 l/min
R422103560	1.3 W	0.27	1.5 l/(s*bar)	310 l/min
R422103567	1.3 W	0.3	0.8 l/(s*bar)	180 l/min
R422103568	1.3 W	0.27	1.5 l/(s*bar)	310 l/min

Part No.	Working pressure min./max.	Typ. switch-on time	Typ. switch-off time	Weight
R422103559	3 ... 7 bar	10 ms	22 ms	0.053 kg
R422103560	3 ... 7 bar	10 ms	22 ms	0.053 kg
R422103567	2 ... 7 bar	9 ms	9 ms	0.063 kg
R422103568	2 ... 7 bar	9 ms	9 ms	0.063 kg

Nominal flow Qn at 6 bar and $\Delta p = 1$ bar, MO = Manual override

Technical information

The min. control pressure must be adhered to, since otherwise faulty switching and valve failure may result!

The pressure dew point must be at least 15 °C under ambient and medium temperature and may not exceed 3 °C .

The oil content of compressed air must remain constant during the life cycle.

Use only the approved oils from AVENTICS. Further information can be found in the "Technical information" document (available in the MediaCentre).

A duty cycle of 100 percent is only valid for single valves.

Technical information

Material	
Housing	Polyoxymethylene
Seals	Acrylonitrile butadiene rubber Hydrogenated nitrile butadiene rubber Polyurethane

Dimensions

dimensions, single solenoid

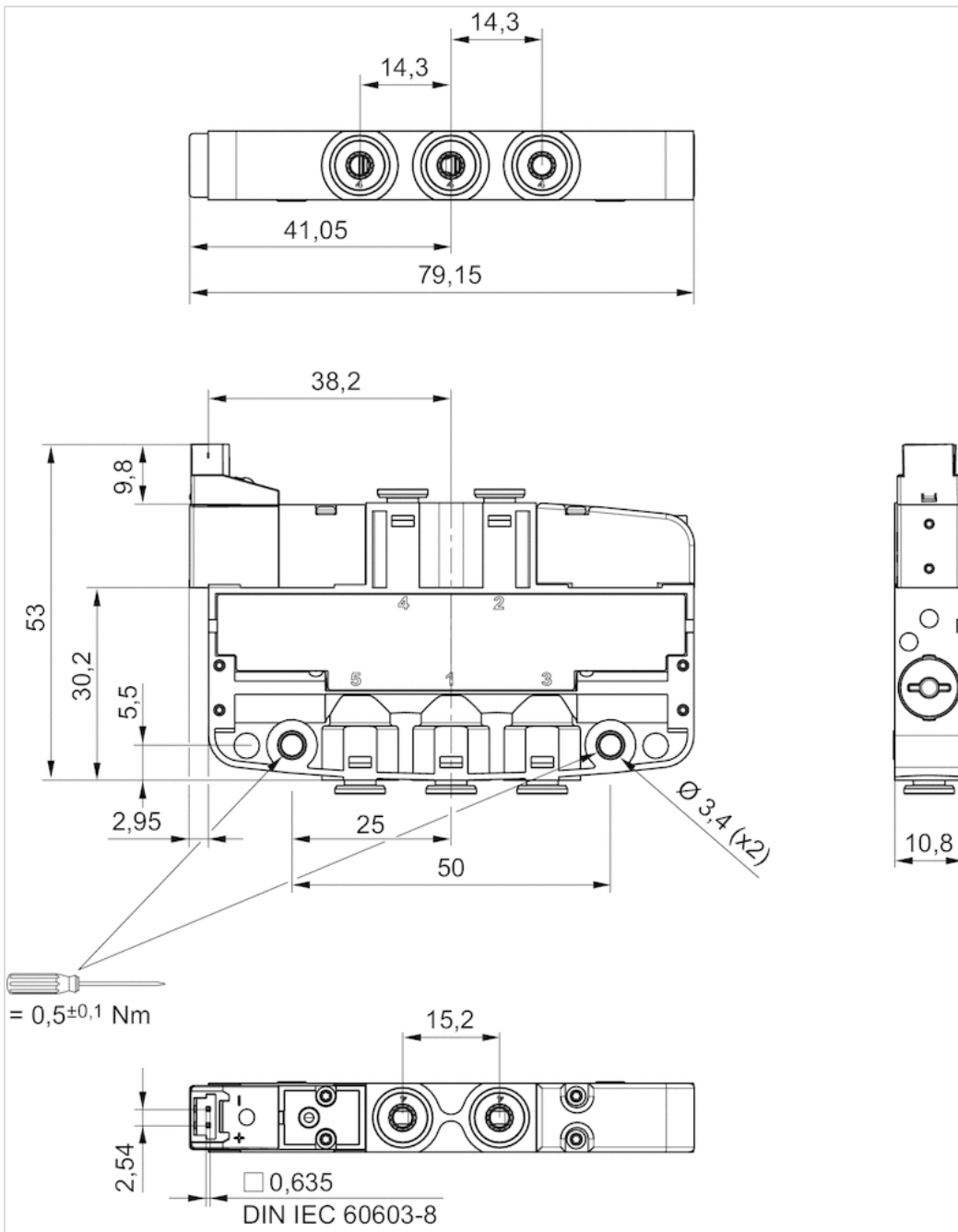

dimensions, double solenoid

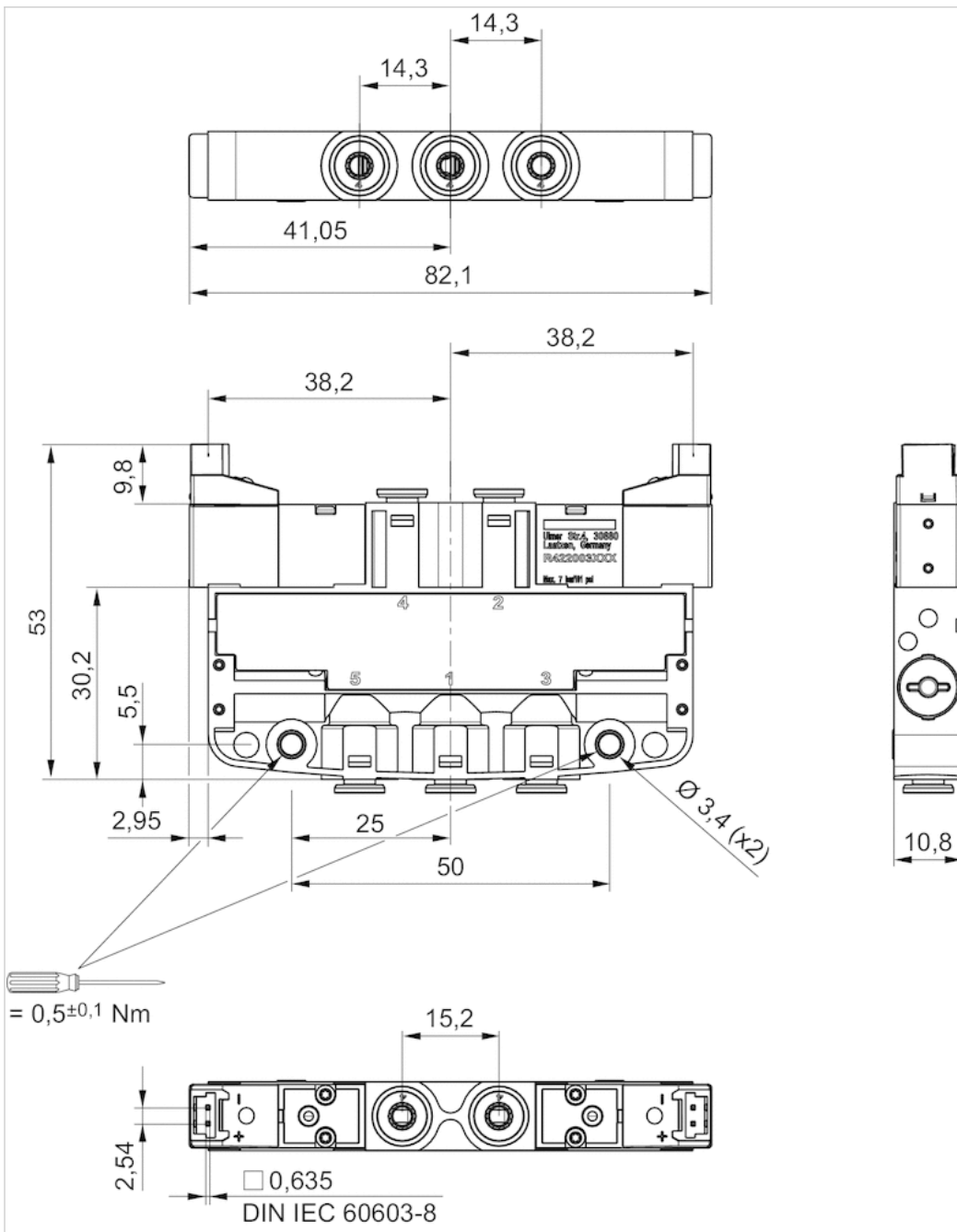

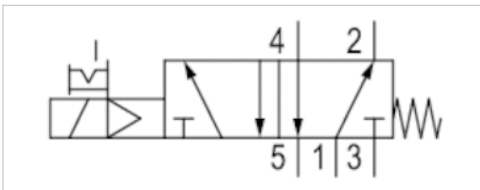

5/2-directional valve, Series LS04-AF

- 5/2
- Qn = 180-310 l/min
- Pipe connection
- Compressed air connection output : Ø 4 Ø 6
- Electrical connection : Plug, Industrial plug connector, 2-pin
- Manual override : with detent
- single solenoid
- With spring return
- Pilot : Internal



Version	Spool valve, positive overlapping
Activation	Electrically
Pilot	Internal
Sealing principle	Soft sealing
Working pressure min./max.	3 ... 7 bar
Ambient temperature min./max.	-10 ... 50 °C
Medium temperature min./max.	-10 ... 50 °C
Medium	Compressed air
Max. particle size	5 µm
Oil content of compressed air	0 ... 5 mg/m ³
Nominal flow Qn	See table below
Protection class acc. to DIN EN 61140 Electrically	Class III
Protection class with connection	IP50
Protective circuit	Z-diode
LED status display	Yellow
Duty cycle	100 %
Typ. switch-on time	10 ms
Typ. switch-off time	22 ms
Generic emission standard in accordance with	EN 61000-6-4:2002
Generic immunity standard in accordance with	IEC 61000-6-2:2005
mounting screws	M3
Mounting screw tightening torque	0.5 Nm
Weight	0.053 kg

Technical data

Part No.	MO	Compressed air connection	
		Input	Output
R422103563		Ø 4	Ø 4
R422103564		Ø 6	Ø 6

Part No.	Compressed air connection		Operational voltage	Voltage tolerance
	Exhaust			
R422103563	Ø 4		DC 24 V	DC -10% / +10%
R422103564	Ø 6		DC 24 V	DC -10% / +10%

Part No.	Power consumption	Flow conductance	Flow conductance	Nominal flow Qn
	DC	b	C-value	
R422103563	1.3 W	0.3	0.8 l/(s*bar)	180 l/min
R422103564	1.3 W	0.27	1.5 l/(s*bar)	310 l/min

Nominal flow Qn at 6 bar and $\Delta p = 1$ bar, MO = Manual override

Technical information

The min. control pressure must be adhered to, since otherwise faulty switching and valve failure may result!

The pressure dew point must be at least 15 °C under ambient and medium temperature and may not exceed 3 °C .

The oil content of compressed air must remain constant during the life cycle.

Use only the approved oils from AVENTICS. Further information can be found in the "Technical information" document (available in the MediaCentre).

A duty cycle of 100 percent is only valid for single valves.

Technical information

Material	
Housing	Polyoxymethylene
Seals	Acrylonitrile butadiene rubber Hydrogenated nitrile butadiene rubber Polyurethane

Dimensions

dimensions, single solenoid

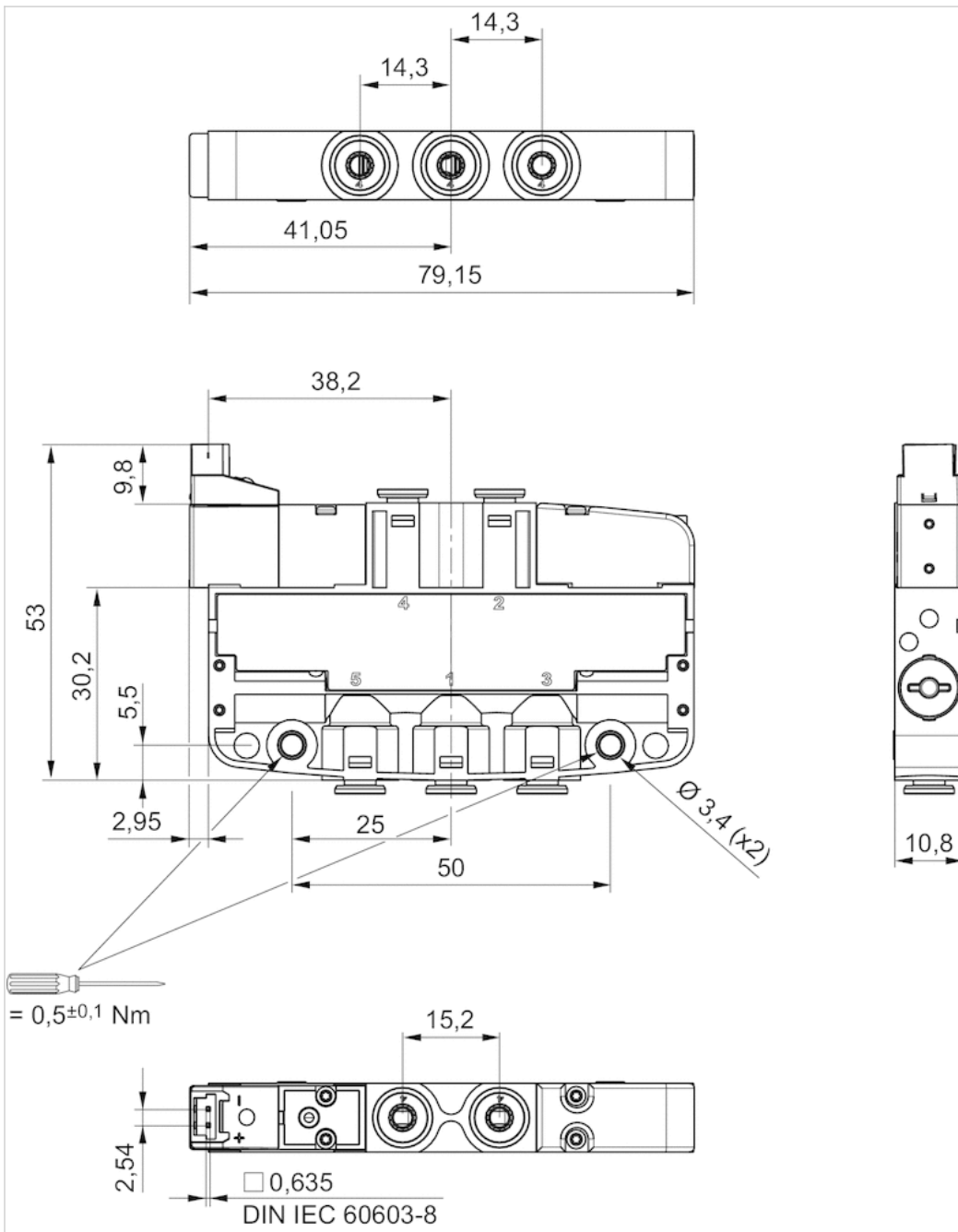

5/2 directional valve, series LS04-PD

- with position detection
- 5/2
- $Q_n = 180-310$ l/min
- Pipe connection
- Compressed air connection output : $\varnothing 4 \varnothing 6$
- Electrical connection : M8, 3-pin
- Manual override : without detent
- single solenoid
- With spring return
- Pilot : Internal

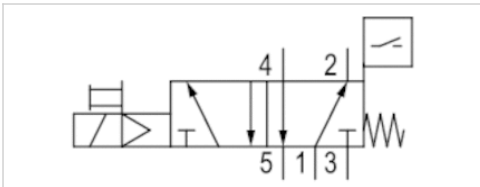

Type	Spool valve, positive overlapping
Activation	Electrically
Pilot	Internal
Sealing principle	Soft sealing
Working pressure min./max.	3 ... 7 bar
Ambient temperature min./max.	-10 ... 50 °C
Medium temperature min./max.	-10 ... 50 °C
Medium	Compressed air
Max. particle size	5 μ m
Oil content of compressed air	0 ... 5 mg/m ³
Nominal flow Q_n	See table below
Connector standard	DIN EN 60947-5-2
Protection class acc. to DIN EN 61140	Class III
Electrically	
Protection class with connection	IP65
Protective circuit	Z-diode
LED status display	Yellow
Typ. switch-on time	10 ms
Typ. switch-off time	22 ms
Generic emission standard in accordance with	EN 61000-6-4:2002
Generic immunity standard in accordance with	IEC 61000-6-2:2005
Type sensor	electronic PNP, with LED
Sensor Electrical interface	M8, 3-pin
Operating voltage sensor DC min./max.	10 ... 30 V DC
Voltage drop sensor U at I_{max}	$\leq 2,0$ V
mounting screws	M3
Mounting screw tightening torque	0,5 Nm
Weight	0,053 kg
Comment	The delivered product may vary from that in the illustration.

Technical data

Part No.	Compressed air connection	
	Input	Output
R422005156	Ø 4	Ø 4
R422005155	Ø 6	Ø 6

Part No.	Compressed air connection	Operational voltage	Voltage tolerance
	Exhaust	DC	DC
R422005156	Ø 4	24 V	-10% / +10%
R422005155	Ø 6	24 V	-10% / +10%

Part No.	Power consumption	Flow conductance	Flow conductance	Nominal flow Qn
	DC	b	C-value	
R422005156	1,3 W	0,3	0,8 l/(s*bar)	180 l/min
R422005155	1,3 W	0,27	1,5 l/(s*bar)	310 l/min

Nominal flow Qn at 6 bar and $\Delta p = 1$ bar, MO = Manual override

Technical information

The min. control pressure must be adhered to, since otherwise faulty switching and valve failure may result!
 The pressure dew point must be at least 15 °C under ambient and medium temperature and may not exceed 3 °C .
 The oil content of compressed air must remain constant during the life cycle.
 Use only the approved oils from AVENTICS. Further information can be found in the "Technical information" document (available in the MediaCentre).

A duty cycle of 100% is only valid for valves mounted separately.
 If the solenoid valve is switched off, the flow direction is from connection 4 to 5, 1 to 2. The sensor output signal is high and the red LED is illuminated. The maximum sensor current is 12 mA.

Technical information

Material	
Housing	Polyoxymethylene
Seals	Acrylonitrile butadiene rubber Hydrogenated nitrile butadiene rubber Polyurethane

Dimensions

Dimensions

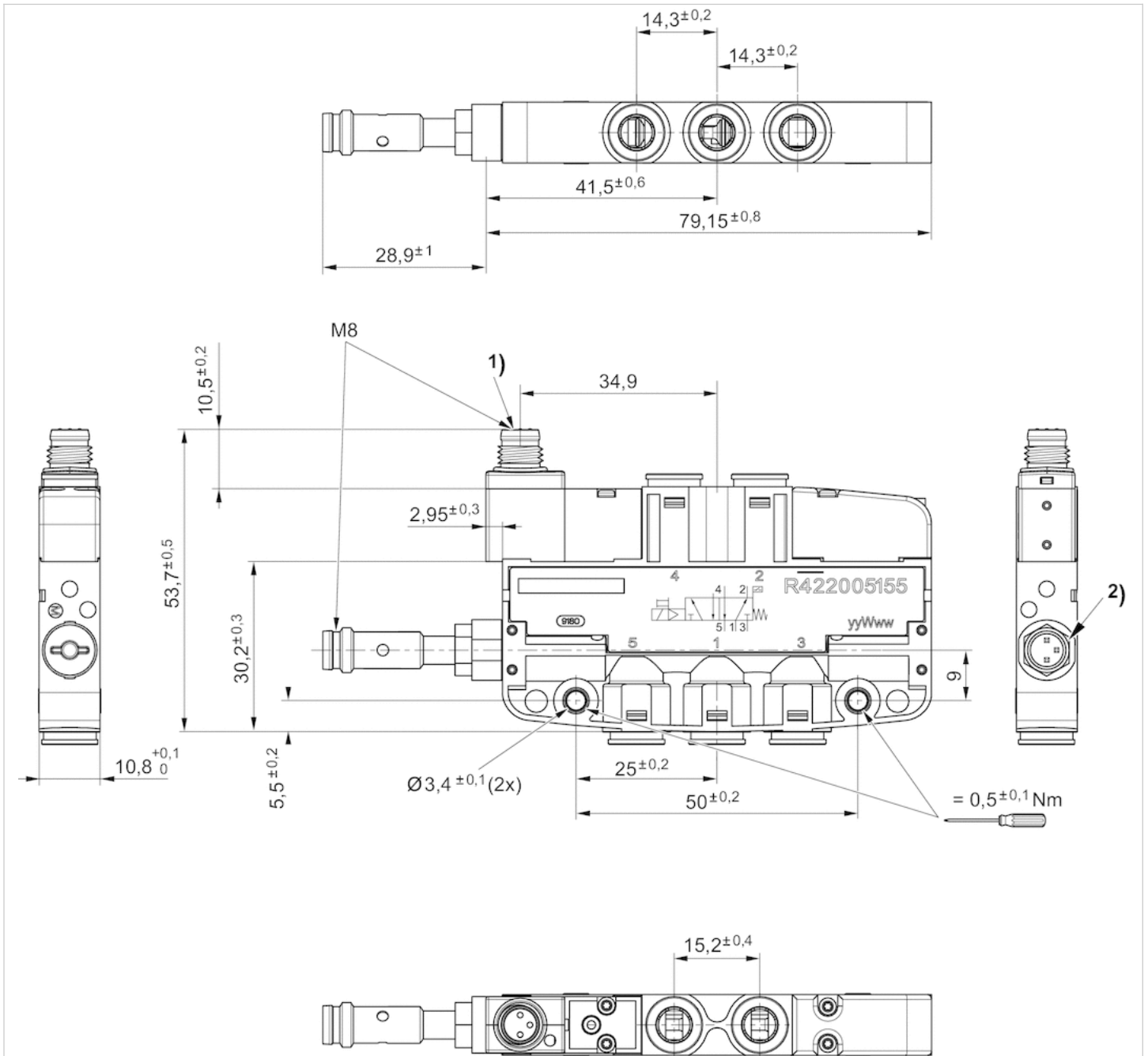

- 1) Valve plug connector M8
- 2) Sensor plug M8, 3-pin

Pin assignments

PIN assignment for valve plug connectors, 3-pin

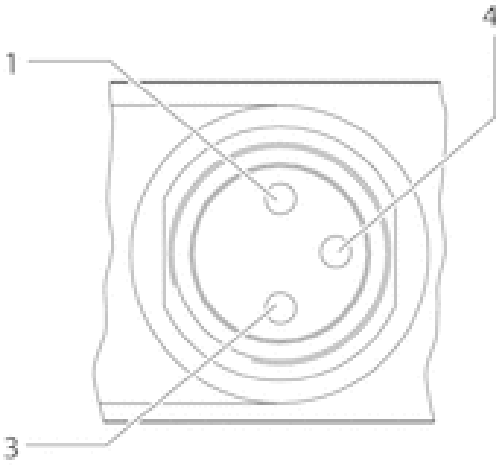

- 1) Pin not assigned
- 3) 0 V
- 4) 24 V

Note: Bi-polar protective circuit to prevent overvoltage

PIN assignment sensor, plug M8, 3-pin

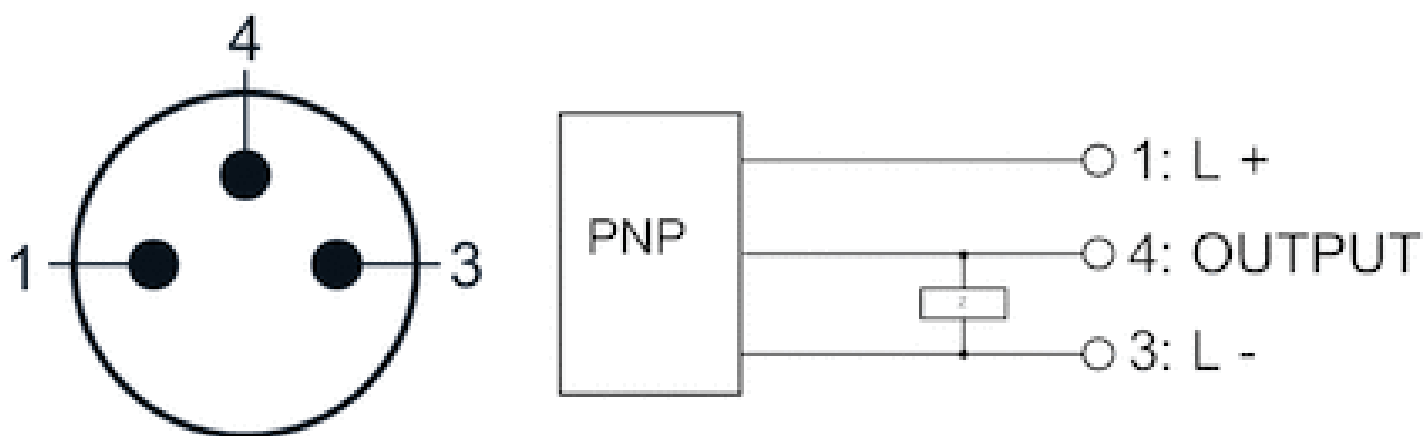





5/2-directional valve, Series LS04-XS

- 5/2
- Qn = 200 l/min
- Pipe connection
- Compressed air connection output : Ø 4
- Electrical connection : Plug, Industrial plug connector, 2-pin
- Manual override : with detent without detent
- single solenoid
- With spring return
- Pilot : Internal



Version	Spool valve, positive overlapping
Activation	Electrically
Pilot	Internal
Sealing principle	Soft sealing
Working pressure min./max.	3 ... 7 bar
Ambient temperature min./max.	-10 ... 50 °C
Medium temperature min./max.	-10 ... 50 °C
Medium	Compressed air
Max. particle size	5 µm
Oil content of compressed air	0 ... 5 mg/m ³
Nominal flow Qn	200 l/min
Protection class acc. to DIN EN 61140	Class III
Electrically	
Protection class with connection	IP50
Protective circuit	Z-diode
LED status display	Yellow
Duty cycle	100 %
Typ. switch-on time	9 ms
Typ. switch-off time	18 ms
Generic emission standard in accordance with	EN 61000-6-4:2002
Generic immunity standard in accordance with	IEC 61000-6-2:2005
mounting screws	M3
Mounting screw tightening torque	0.5 Nm
Weight	0.04 kg

Technical data

Part No.		MO	Compressed air connection	
			Input	Output
R422103557			Ø 4	Ø 4
R422103555			Ø 4	Ø 4

Part No.	Compressed air connection		Operational voltage	Voltage tolerance
	Exhaust			
R422103557	Ø 4		DC	DC
R422103555	Ø 4		24 V	-10% / +10%
R422103555	Ø 4		24 V	-10% / +10%

Part No.	Power consumption	Flow conductance	Flow conductance
	DC	b	C-value
R422103557	1.3 W	0.4	0.8 l/(s*bar)
R422103555	1.3 W	0.4	0.8 l/(s*bar)

Nominal flow Qn at 6 bar and $\Delta p = 1$ bar, MO = Manual override

Technical information

The min. control pressure must be adhered to, since otherwise faulty switching and valve failure may result!

The pressure dew point must be at least 15 °C under ambient and medium temperature and may not exceed 3 °C .

The oil content of compressed air must remain constant during the life cycle.

Use only the approved oils from AVENTICS. Further information can be found in the "Technical information" document (available in the MediaCentre).

A duty cycle of 100 percent is only valid for single valves.

Technical information

Material	
Housing	Aluminum Polyoxymethylene
Seals	Acrylonitrile butadiene rubber Hydrogenated nitrile butadiene rubber Polyurethane

Dimensions

Dimensions

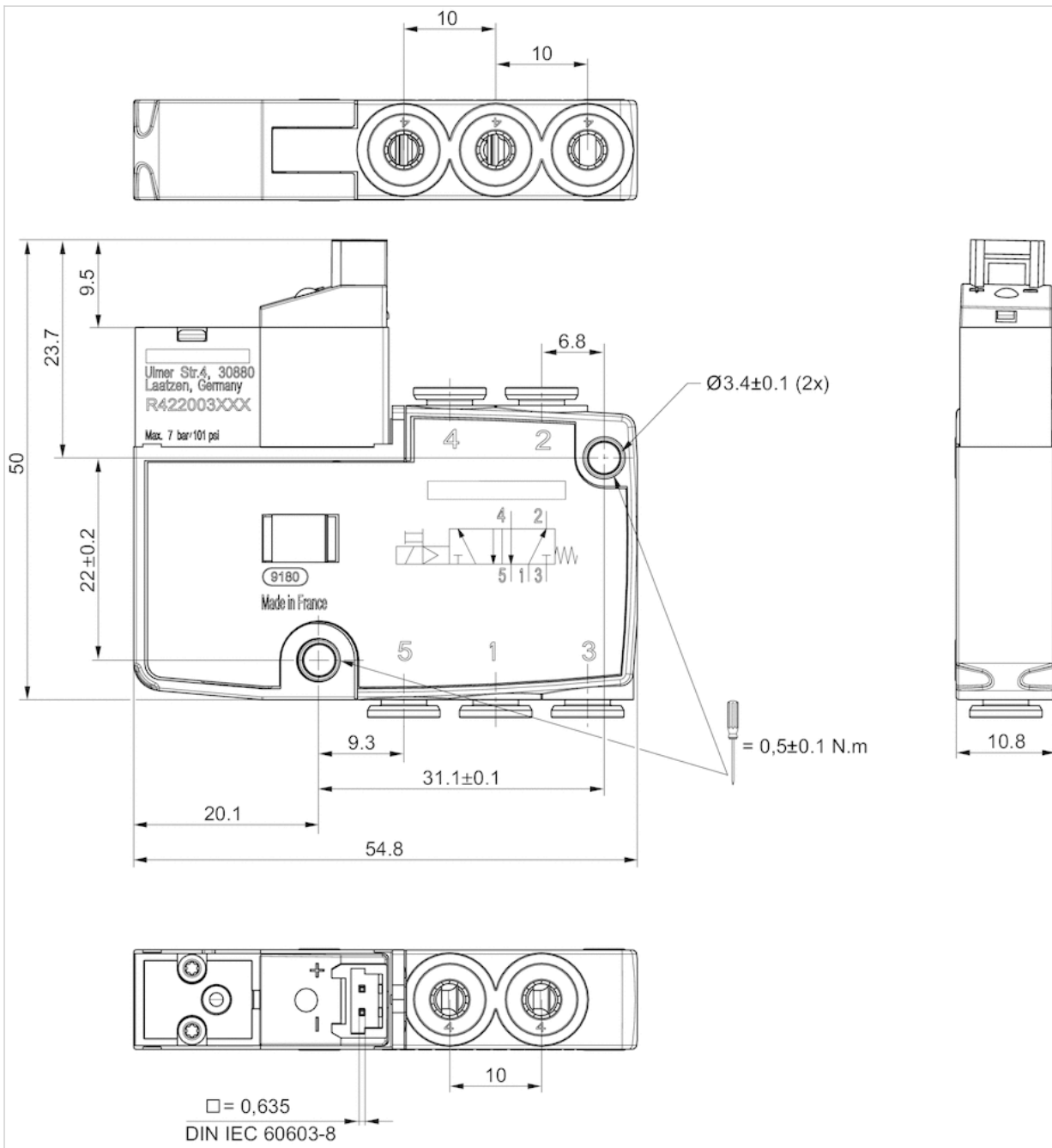





5/2-directional valve, Series LS04-XS

- 5/2
- Qn = 200 l/min
- Pipe connection
- Compressed air connection output : Ø 4
- Electrical connection : Plug, M8, 3-pin
- Manual override : with detent, without detent
- single solenoid
- With spring return
- Pilot : Internal



Version	Spool valve, positive overlapping
Activation	Electrically
Pilot	Internal
Sealing principle	Soft sealing
Working pressure min./max.	3 ... 7 bar
Ambient temperature min./max.	-10 ... 50 °C
Medium temperature min./max.	-10 ... 50 °C
Medium	Compressed air
Max. particle size	5 µm
Oil content of compressed air	0 ... 5 mg/m ³
Nominal flow Qn	200 l/min
Connector standard	DIN EN 60947-5-2
Protection class acc. to DIN EN 61140	Class III
Electrically	
Protection class with connection	IP65
Protective circuit	Z-diode
LED status display	Yellow
Duty cycle	100 %
Typ. switch-on time	9 ms
Typ. switch-off time	18 ms
Generic emission standard in accordance with	EN 61000-6-4:2002
Generic immunity standard in accordance with	IEC 61000-6-2:2005
mounting screws	M3
Mounting screw tightening torque	0.5 Nm
Weight	0.04 kg

Technical data

Part No.		MO	Compressed air connection	
			Input	Output
R422103556			Ø 4	Ø 4
R422103558			Ø 4	Ø 4

Part No.	Compressed air connection		Operational voltage	Voltage tolerance
	Exhaust			
R422103556	Ø 4		DC 24 V	DC -10% / +10%
R422103558	Ø 4		DC 24 V	DC -10% / +10%

Part No.	Power consumption		Flow conductance	
	DC		b	C-value
R422103556	1.3 W		0.4	0.8 l/(s*bar)
R422103558	1.3 W		0.4	0.8 l/(s*bar)

Nominal flow Q_n at 6 bar and Δp = 1 bar, MO = Manual override

Technical information

The min. control pressure must be adhered to, since otherwise faulty switching and valve failure may result!

The pressure dew point must be at least 15 °C under ambient and medium temperature and may not exceed 3 °C .

The oil content of compressed air must remain constant during the life cycle.

Use only the approved oils from AVENTICS. Further information can be found in the "Technical information" document (available in the MediaCentre).

A duty cycle of 100 percent is only valid for single valves.

Technical information

Material	
Housing	Aluminum Polyoxymethylene
Seals	Acrylonitrile butadiene rubber Hydrogenated nitrile butadiene rubber Polyurethane

Dimensions

Dimensions

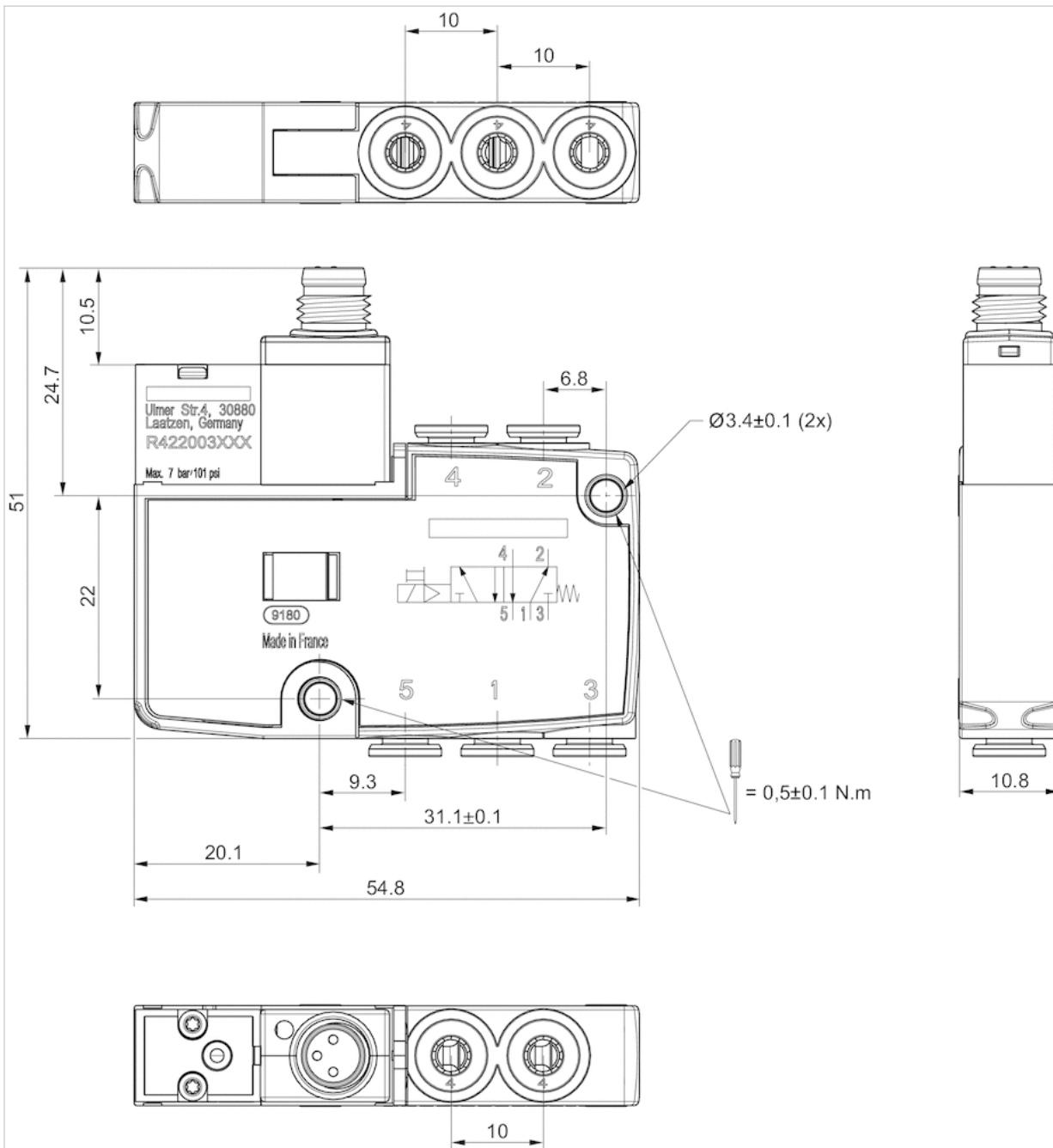

Pin assignments

PIN assignment for valve plug connectors

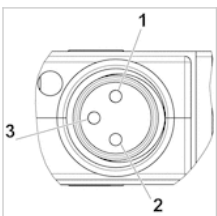

- 1) DC -/+
- 2) not assigned

3) DC -/+

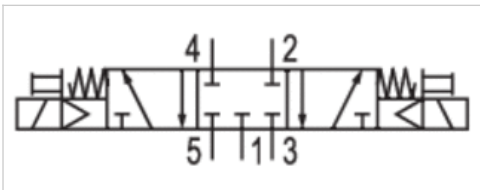

5/3-directional valve, Series LS04-AF

- 5/3
- $Q_n = 170-270 \text{ l/min}$
- closed center
- Pipe connection
- Compressed air connection output : $\varnothing 4 \varnothing 6$
- Electrical connection : 2, Plug, M8, 3-pin
- Manual override : without detent
- double solenoid
- Pilot : Internal



Version	Spool valve, positive overlapping
Activation	Electrically
Pilot	Internal
Sealing principle	Soft sealing
Working pressure min./max.	3 ... 7 bar
Ambient temperature min./max.	-10 ... 50 °C
Medium temperature min./max.	-10 ... 50 °C
Medium	Compressed air
Max. particle size	5 μm
Oil content of compressed air	0 ... 5 mg/m^3
Nominal flow Q_n	See table below
Connector standard	DIN EN 60947-5-2
Protection class acc. to DIN EN 61140	Class III
Electrically	
Protection class with connection	IP65
Protective circuit	Z-diode
LED status display	Yellow
Duty cycle	100 %
Typ. switch-on time	10 ms
Generic emission standard in accordance with	EN 61000-6-4:2002
Generic immunity standard in accordance with	IEC 61000-6-2:2005
mounting screws	M3
Mounting screw tightening torque	0.5 Nm
Weight	0.063 kg

Technical data

Part No.	MO		Compressed air connection	
				Input
R422103842			closed center	Ø 4
R422103843			closed center	Ø 6

Part No.	Compressed air connection		Compressed air connection
	Output		Exhaust
R422103842	Ø 4		Ø 4
R422103843	Ø 6		Ø 6

Part No.	Operational voltage	Voltage tolerance	Power consumption
	DC	DC	DC
R422103842	24 V	-10% / +10%	1.3 W
R422103843	24 V	-10% / +10%	1.3 W

Part No.	Flow conductance	Flow conductance	Nominal flow Qn
	b	C-value	
R422103842	0.4	0.8 l/(s*bar)	170 l/min
R422103843	0.3	1.3 l/(s*bar)	270 l/min

Nominal flow Qn at 6 bar and $\Delta p = 1$ bar, MO = Manual override

Technical information

The min. control pressure must be adhered to, since otherwise faulty switching and valve failure may result!

The pressure dew point must be at least 15 °C under ambient and medium temperature and may not exceed 3 °C .

The oil content of compressed air must remain constant during the life cycle.

Use only the approved oils from AVENTICS. Further information can be found in the "Technical information" document (available in the MediaCentre).

A duty cycle of 100 percent is only valid for single valves.

Technical information

Material	
Housing	Polyoxymethylene
Seals	Acrylonitrile butadiene rubber Hydrogenated nitrile butadiene rubber Polyurethane

Dimensions

Dimensions, double solenoid

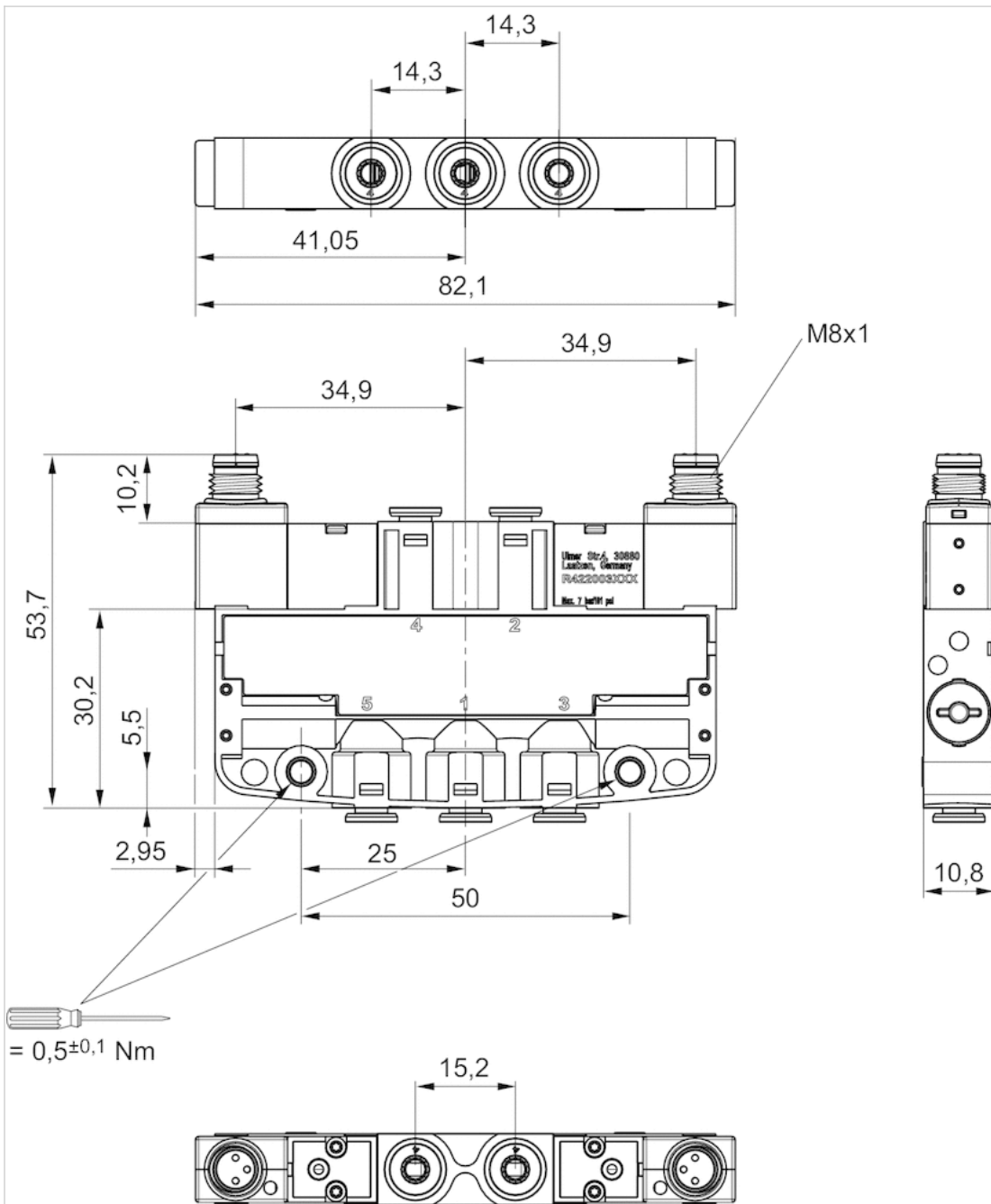

Pin assignments

PIN assignment for valve plug connectors

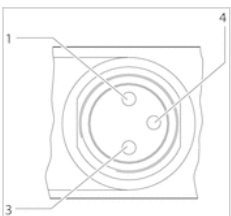

- 1) Pin not assigned
- 3) 0 V

4) 24 V

Note: Bi-polar protective circuit to prevent overvoltage

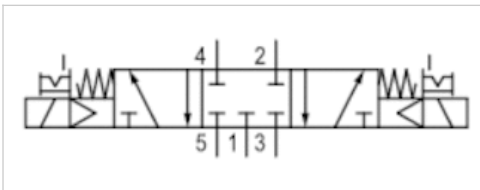

5/3-directional valve, Series LS04-AF

- 5/3
- $Q_n = 170-270$ l/min
- closed center
- Pipe connection
- Compressed air connection output : $\varnothing 4 \varnothing 6$
- Electrical connection : 2, Plug, M8, 3-pin
- Manual override : with detent
- double solenoid
- Pilot : Internal



Version	Spool valve, positive overlapping
Activation	Electrically
Pilot	Internal
Sealing principle	Soft sealing
Working pressure min./max.	3 ... 7 bar
Ambient temperature min./max.	-10 ... 50 °C
Medium temperature min./max.	-10 ... 50 °C
Medium	Compressed air
Max. particle size	5 µm
Oil content of compressed air	0 ... 5 mg/m ³
Nominal flow Q_n	See table below
Connector standard	DIN EN 60947-5-2
Protection class acc. to DIN EN 61140	Class III
Electrically	
Protection class with connection	IP65
Protective circuit	Z-diode
LED status display	Yellow
Duty cycle	100 %
Typ. switch-on time	10 ms
Generic emission standard in accordance with	EN 61000-6-4:2002
Generic immunity standard in accordance with	IEC 61000-6-2:2005
mounting screws	M3
Mounting screw tightening torque	0.5 Nm
Weight	0.063 kg

Technical data

Part No.	MO		Compressed air connection	
			Input	
R422103846		closed center	Ø 4	
R422103847		closed center	Ø 6	

Part No.	Compressed air connection		Compressed air connection	
	Output		Exhaust	
R422103846	Ø 4		Ø 4	
R422103847	Ø 6		Ø 6	

Part No.	Operational voltage	Voltage tolerance		Power consumption	
		DC	DC	DC	DC
R422103846	24 V	-10% / +10%		1.3 W	
R422103847	24 V	-10% / +10%		1.3 W	

Part No.	Flow conductance		Flow conductance		Nominal flow Qn
	b		C-value		
R422103846	0.4		0.8 l/(s*bar)		170 l/min
R422103847	0.3		1.3 l/(s*bar)		270 l/min

Nominal flow Qn at 6 bar and $\Delta p = 1$ bar, MO = Manual override

Technical information

The min. control pressure must be adhered to, since otherwise faulty switching and valve failure may result!

The pressure dew point must be at least 15 °C under ambient and medium temperature and may not exceed 3 °C .

The oil content of compressed air must remain constant during the life cycle.

Use only the approved oils from AVENTICS. Further information can be found in the "Technical information" document (available in the MediaCentre).

A duty cycle of 100 percent is only valid for single valves.

Technical information

Material	
Housing	Polyoxymethylene
Seals	Acrylonitrile butadiene rubber Hydrogenated nitrile butadiene rubber Polyurethane

Dimensions

Dimensions, double solenoid

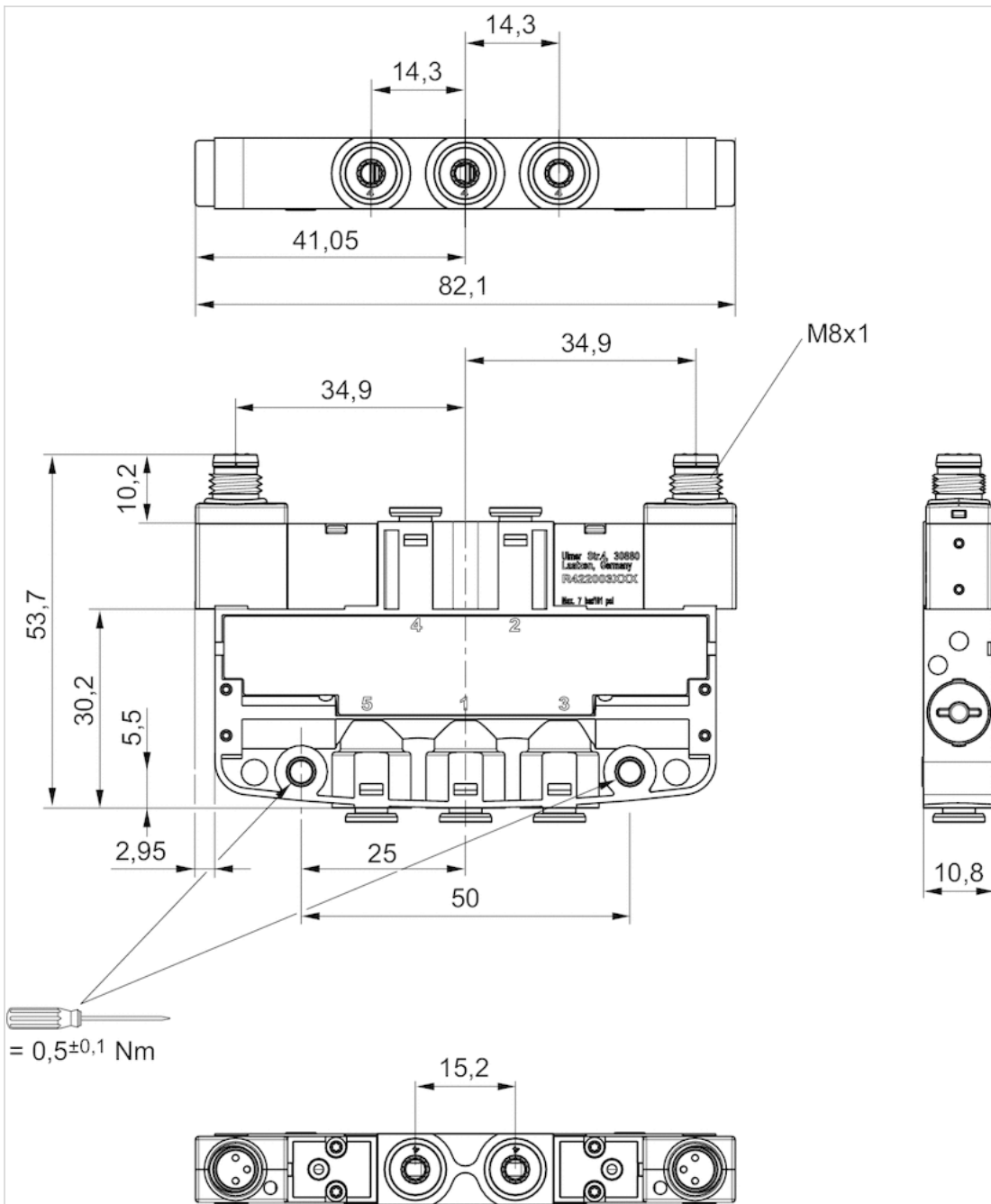

Pin assignments

PIN assignment for valve plug connectors

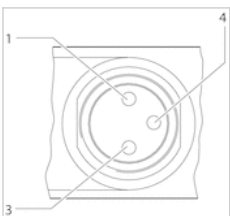

- 1) Pin not assigned
- 3) 0 V

4) 24 V

Note: Bi-polar protective circuit to prevent overvoltage

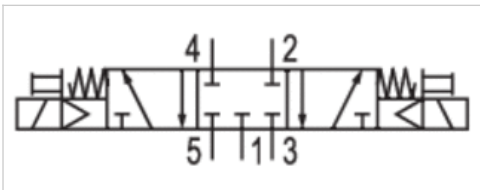

5/3-directional valve, Series LS04-AF

- 5/3
- Qn = 170-270 l/min
- closed center
- Pipe connection
- Compressed air connection output : Ø 4 Ø 6
- Electrical connection : 2, Plug, Industrial plug connector, 2-pin
- Manual override : without detent
- double solenoid
- Pilot : Internal



Version	Spool valve, positive overlapping
Activation	Electrically
Pilot	Internal
Sealing principle	Soft sealing
Working pressure min./max.	3 ... 7 bar
Ambient temperature min./max.	-10 ... 50 °C
Medium temperature min./max.	-10 ... 50 °C
Medium	Compressed air
Max. particle size	5 µm
Oil content of compressed air	0 ... 5 mg/m ³
Nominal flow Qn	See table below
Protection class acc. to DIN EN 61140 Electrically	Class III
Protection class with connection	IP50
Protective circuit	Z-diode
LED status display	Yellow
Duty cycle	100 %
Typ. switch-on time	10 ms
Generic emission standard in accordance with	EN 61000-6-4:2002
Generic immunity standard in accordance with	IEC 61000-6-2:2005
mounting screws	M3
Mounting screw tightening torque	0.5 Nm
Weight	0.063 kg

Technical data

Part No.	MO		Compressed air connection	
				Input
R422103840			closed center	Ø 4
R422103841			closed center	Ø 6

Part No.	Compressed air connection		Compressed air connection	
	Output		Exhaust	
R422103840	Ø 4		Ø 4	
R422103841	Ø 6		Ø 6	

Part No.	Operational voltage	Voltage tolerance		Power consumption	
		DC		DC	
R422103840	24 V	-10% / +10%		1.3 W	
R422103841	24 V	-10% / +10%		1.3 W	

Part No.	Flow conductance		Flow conductance		Nominal flow Qn
	b		C-value		
R422103840	0.4		0.8 l/(s*bar)		170 l/min
R422103841	0.3		1.3 l/(s*bar)		270 l/min

Nominal flow Qn at 6 bar and $\Delta p = 1$ bar, MO = Manual override

Technical information

The min. control pressure must be adhered to, since otherwise faulty switching and valve failure may result!

The pressure dew point must be at least 15 °C under ambient and medium temperature and may not exceed 3 °C .

The oil content of compressed air must remain constant during the life cycle.

Use only the approved oils from AVENTICS. Further information can be found in the "Technical information" document (available in the MediaCentre).

A duty cycle of 100 percent is only valid for single valves.

Technical information

Material	
Housing	Polyoxymethylene
Seals	Acrylonitrile butadiene rubber Hydrogenated nitrile butadiene rubber Polyurethane

Dimensions

dimensions, double solenoid

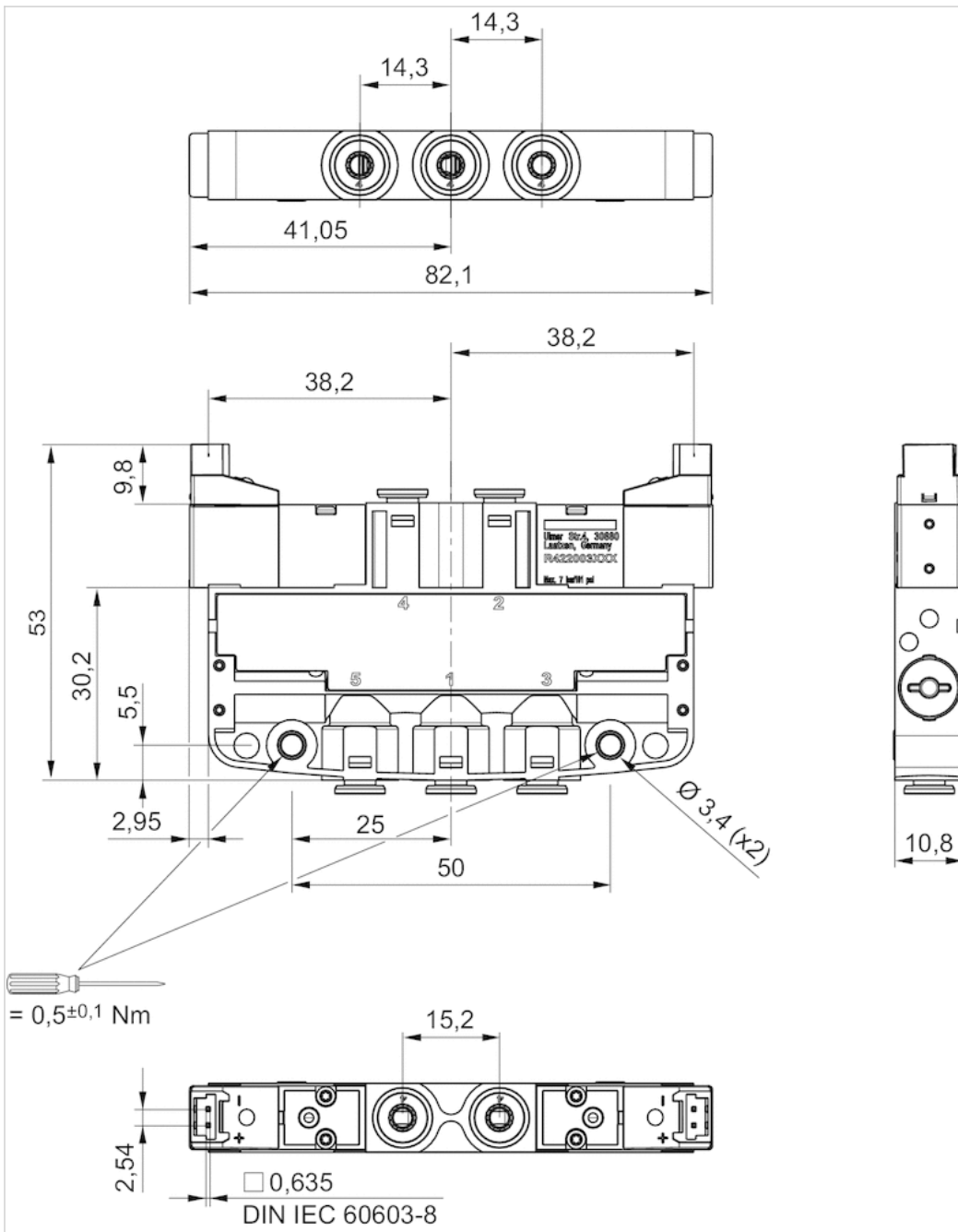

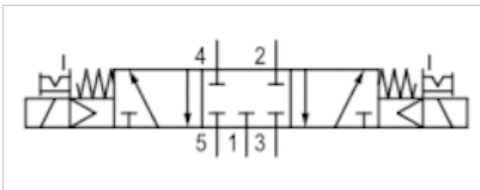

5/3-directional valve, Series LS04-AF

- 5/3
- Qn = 170-270 l/min
- closed center
- Pipe connection
- Compressed air connection output : $\varnothing 4 \varnothing 6$
- Electrical connection : 2, Plug, Industrial plug connector, 2-pin
- Manual override : with detent
- double solenoid
- Pilot : Internal



Version	Spool valve, positive overlapping
Activation	Electrically
Pilot	Internal
Sealing principle	Soft sealing
Working pressure min./max.	3 ... 7 bar
Ambient temperature min./max.	-10 ... 50 °C
Medium temperature min./max.	-10 ... 50 °C
Medium	Compressed air
Max. particle size	5 µm
Oil content of compressed air	0 ... 5 mg/m ³
Nominal flow Qn	See table below
Protection class acc. to DIN EN 61140 Electrically	Class III
Protection class with connection	IP50
Protective circuit	Z-diode
LED status display	Yellow
Duty cycle	100 %
Typ. switch-on time	10 ms
Generic emission standard in accordance with	EN 61000-6-4:2002
Generic immunity standard in accordance with	IEC 61000-6-2:2005
mounting screws	M3
Mounting screw tightening torque	0.5 Nm
Weight	0.063 kg

Technical data

Part No.	MO		Compressed air connection	
			Input	
R422103844		closed center	Ø 4	
R422103845		closed center	Ø 6	

Part No.	Compressed air connection		Compressed air connection	
	Output		Exhaust	
R422103844	Ø 4		Ø 4	
R422103845	Ø 6		Ø 6	

Part No.	Operational voltage	Voltage tolerance		Power consumption	
		DC	DC	DC	DC
R422103844	24 V	-10% / +10%		1.3 W	
R422103845	24 V	-10% / +10%		1.3 W	

Part No.	Flow conductance		Nominal flow Qn
	b	C-value	
R422103844	0.4	0.8 l/(s*bar)	170 l/min
R422103845	0.3	1.3 l/(s*bar)	270 l/min

Nominal flow Qn at 6 bar and $\Delta p = 1$ bar, MO = Manual override

Technical information

The min. control pressure must be adhered to, since otherwise faulty switching and valve failure may result!

The pressure dew point must be at least 15 °C under ambient and medium temperature and may not exceed 3 °C .

The oil content of compressed air must remain constant during the life cycle.

Use only the approved oils from AVENTICS. Further information can be found in the "Technical information" document (available in the MediaCentre).

A duty cycle of 100 percent is only valid for single valves.

Technical information

Material	
Housing	Polyoxymethylene
Seals	Acrylonitrile butadiene rubber Hydrogenated nitrile butadiene rubber Polyurethane

Dimensions

dimensions, double solenoid

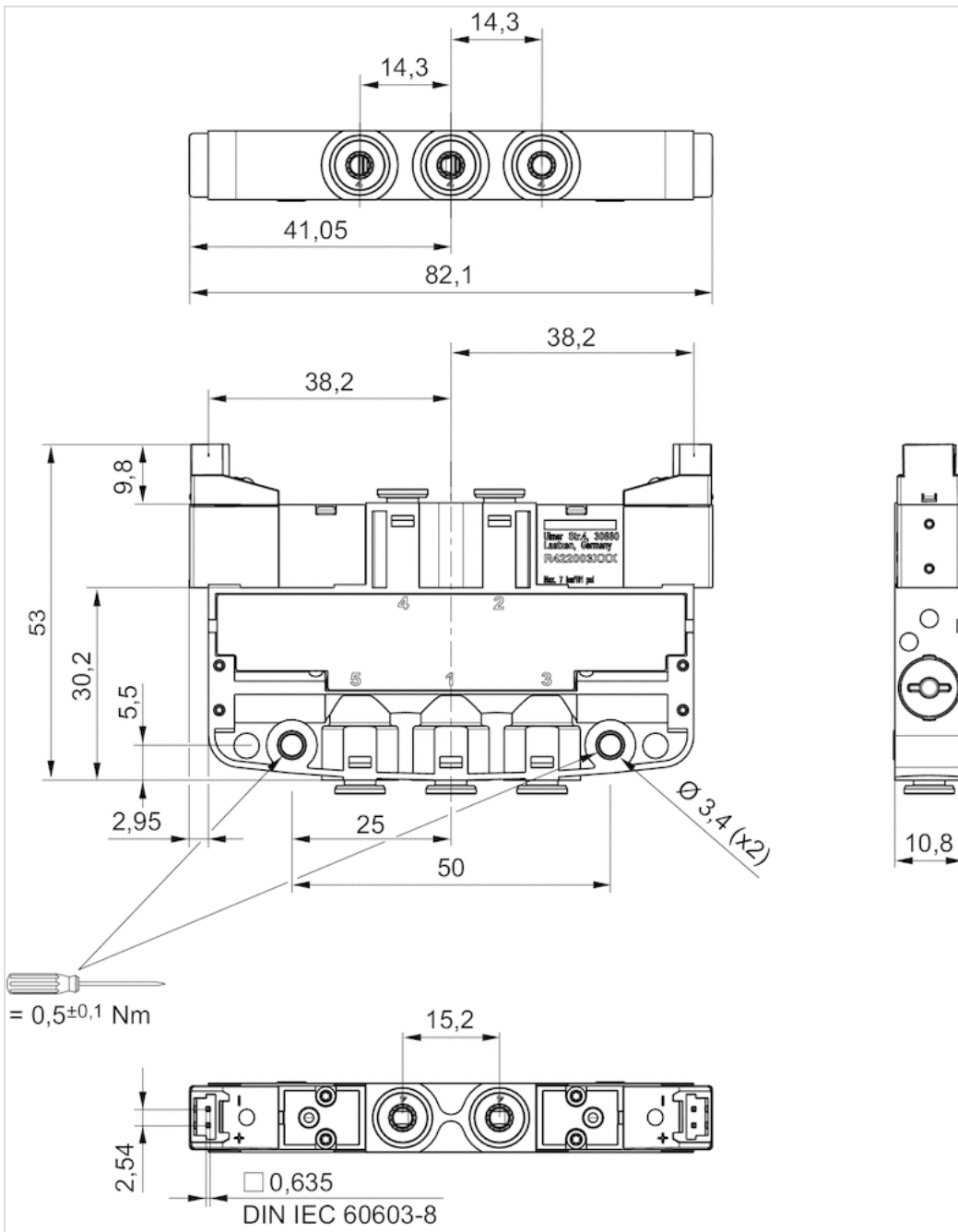

Round plug connector, Series CON-RD

- Socket, M8x1, 3-pin, A-coded, straight, 180°
- UL (Underwriters Laboratories)
- unshielded



Connection type	Soldering
Ambient temperature min./max.	-25 ... 80 °C
Operational voltage	48 V AC/DC
Protection class	IP67
Weight	0.009 kg

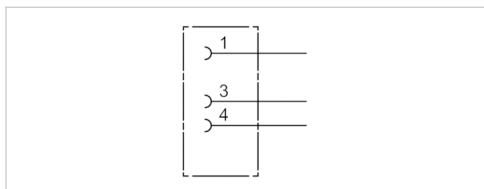

Technical data

Part No.	Max. current	suitable cable-Ø min./max
1834484173	4 A	3.5 / 5 mm

Technical information

The specified protection class is only valid in assembled and tested state.

Technical information

Material	
Housing	Polyamide

Dimensions

Dimensions

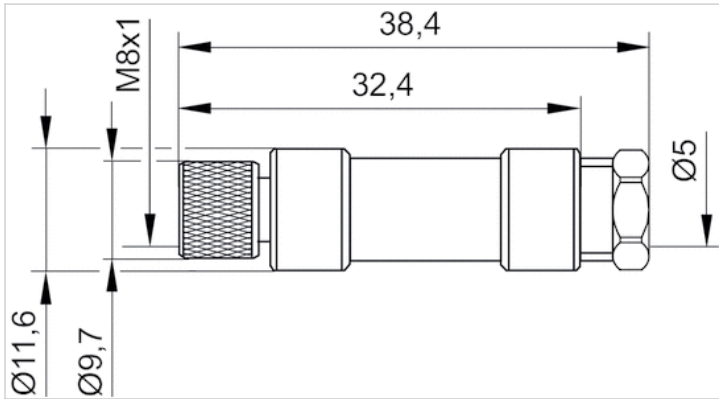

Pin assignments

Pin assignment, socket

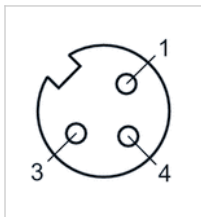

Round plug connector, Series CON-RD

- Socket, M8x1, 3-pin, A-coded, angled, 90°
- UL (Underwriters Laboratories)
- unshielded



Connection type	Soldering
Ambient temperature min./max.	-40 ... 85 °C
Operational voltage	48 V AC/DC
Protection class	IP67
Weight	0.01 kg

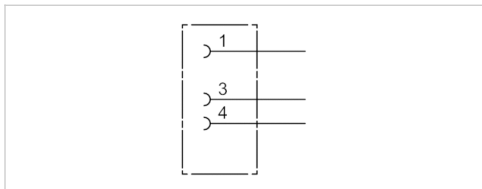

Technical data

Part No.	Max. current	Contact assignment	suitable cable-Ø min./max
1834484174	4 A	3	3.5 / 5 mm

Technical information

The specified protection class is only valid in assembled and tested state.

Technical information

Material	
Housing	Polyamide

Dimensions

Dimensions

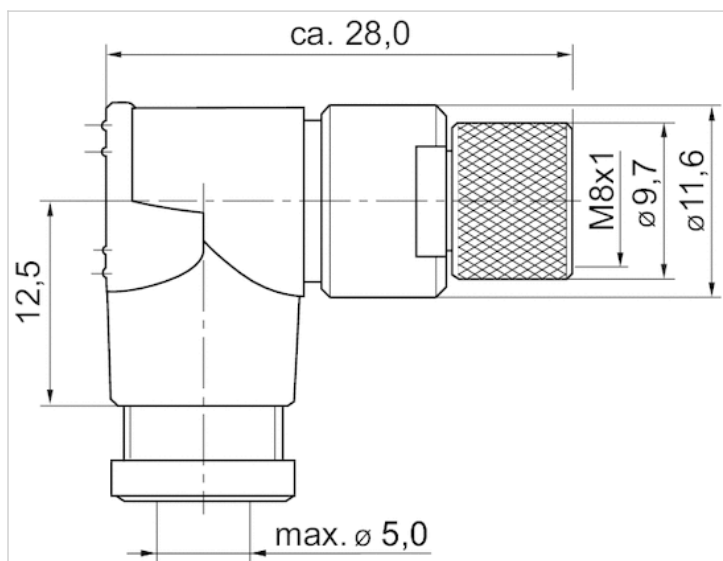

Pin assignments

Pin assignment, socket

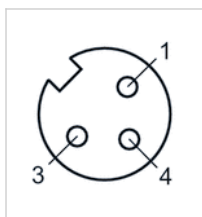

Round plug connector, Series CON-RD

- Socket M8x1 3-pin A-coded straight 180°
- open cable ends
- with cable
- UL (Underwriters Laboratories)
- unshielded

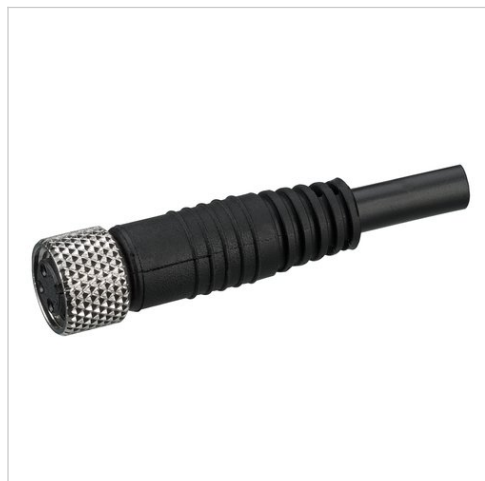

Ambient temperature min./max.	-25 ... 85 °C
Operational voltage	48 V AC/DC
Protection class	IP67
Wire cross-section	0.24 mm ²
Weight	See table below

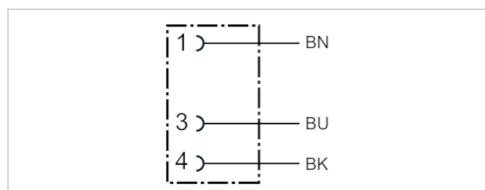

Technical data

Part No.	Max. current	Number of wires	Cable-Ø	Cable length	Certification	Weight
1834484166	4 A	3	4.5 mm	3 m	UL (Underwriters Laboratories)	0.087 kg
1834484168	4 A	3	4.5 mm	5 m	UL (Underwriters Laboratories)	0.141 kg
1834484247	4 A	3	4.5 mm	10 m	UL (Underwriters Laboratories)	0.277 kg

Technical information

The specified protection class is only valid in assembled and tested state.

Technical information

Material	
Housing	Polyurethane
Cable sheath	Polyurethane

Dimensions

Dimensions

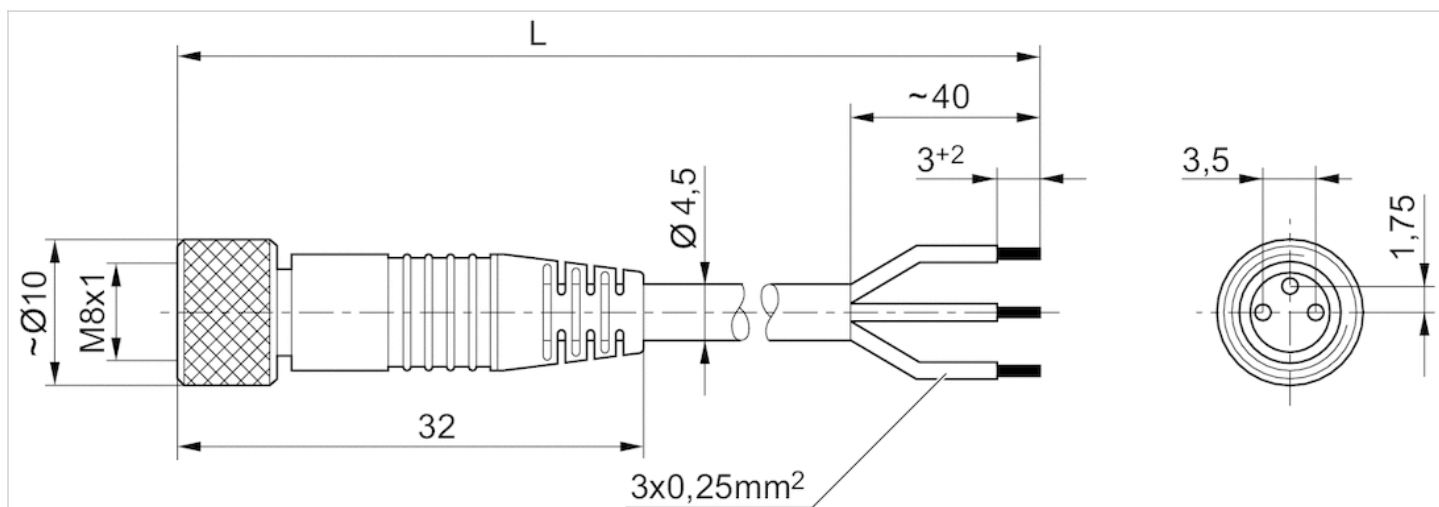

L = length

Pin assignments

Pin assignment, socket

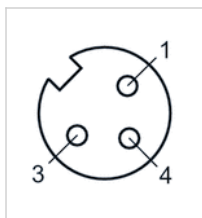

- (1) BN=brown
- (3) BU=blue
- (4) BK=black

Round plug connector, Series CON-RD

- Socket M8x1 3-pin A-coded angled 90°
- open cable ends
- with cable
- unshielded



Ambient temperature min./max.	-40 ... 85 °C
Operational voltage	48 V AC/DC
Protection class	IP67
Wire cross-section	0.24 mm ²
Weight	See table below

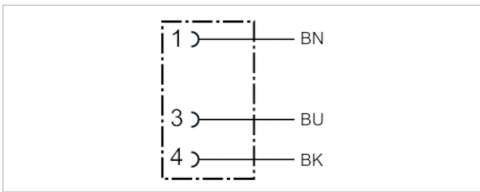

Technical data

Part No.	Max. current	Number of wires	Cable-Ø	Cable length	Weight
1834484167	4 A	3	4.5 mm	3 m	0.087 kg
1834484169	4 A	3	4.5 mm	5 m	0.139 kg
1834484248	4 A	3	4.5 mm	10 m	0.279 kg

Technical information

The specified protection class is only valid in assembled and tested state.

Technical information

Material	
Housing	Polyurethane
Cable sheath	Polyurethane

Dimensions

Dimensions

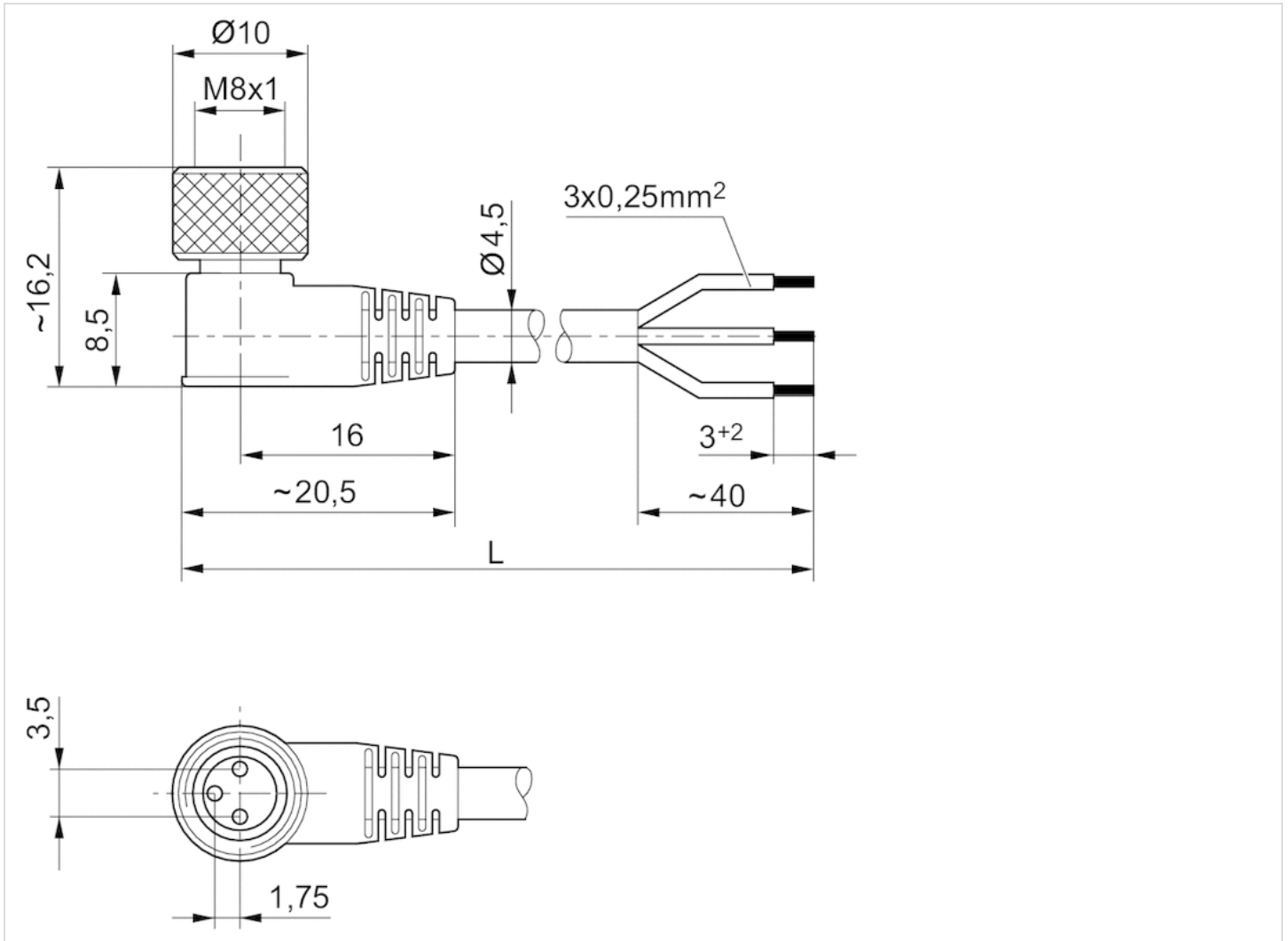

L = length

Pin assignments

Pin assignment, socket

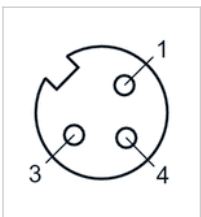

- (1) BN=brown
- (3) BU=blue
- (4) BK=black

Valve plug connector, series CON-VP

- Socket Industrial plug connector 2-pin straight 180°
- with cable
- unshielded



Ambient temperature min./max.	See table below
Operational voltage	48 V AC/DC
Protection class	IP40
Weight	See table below

Technical data

Part No.	Ambient temperature min./max.	Electrical connection
R422003277	-40 ... 80 °C	-
R422003278	-40 ... 80 °C	open cable ends 2-pin
R422003279	-15 ... 80 °C	open cable ends 2-pin
R412024482	-25 ... 80 °C	Plug Industrial plug connector 2-pin straight 180°

Part No.	Number of wires	Wire cross-section	Cable sheath	Cable-Ø	Cable length	Cable
R422003277	-	-	-	-	-	-
R422003278	2	0.25 mm ²	Polyvinyl chloride	1.5 mm	3 m	with cable
R422003279	2	0.25 mm ²	Polyvinyl chloride	1.5 mm	5 m	with cable
R412024482	2	0.25 mm ²	Polyvinyl chloride	1.5 mm	0.6 m	with cable

Part No.	Connection type	Delivery unit	Weight	Fig.	
R422003277	Crimping	10 piece	0.001 kg	Fig. 1	1)
R422003278	-	1 piece	0.026 kg	Fig. 1	-
R422003279	-	1 piece	0.042 kg	Fig. 1	-
R412024482	-	1 piece	0.002 kg	Fig. 2	2)

1) without cable

2) Adapter cable for industrial plug-in fittings

Technical information

Material	
Cable sheath	Polyvinyl chloride

Dimensions

Dimensions, Fig. 1

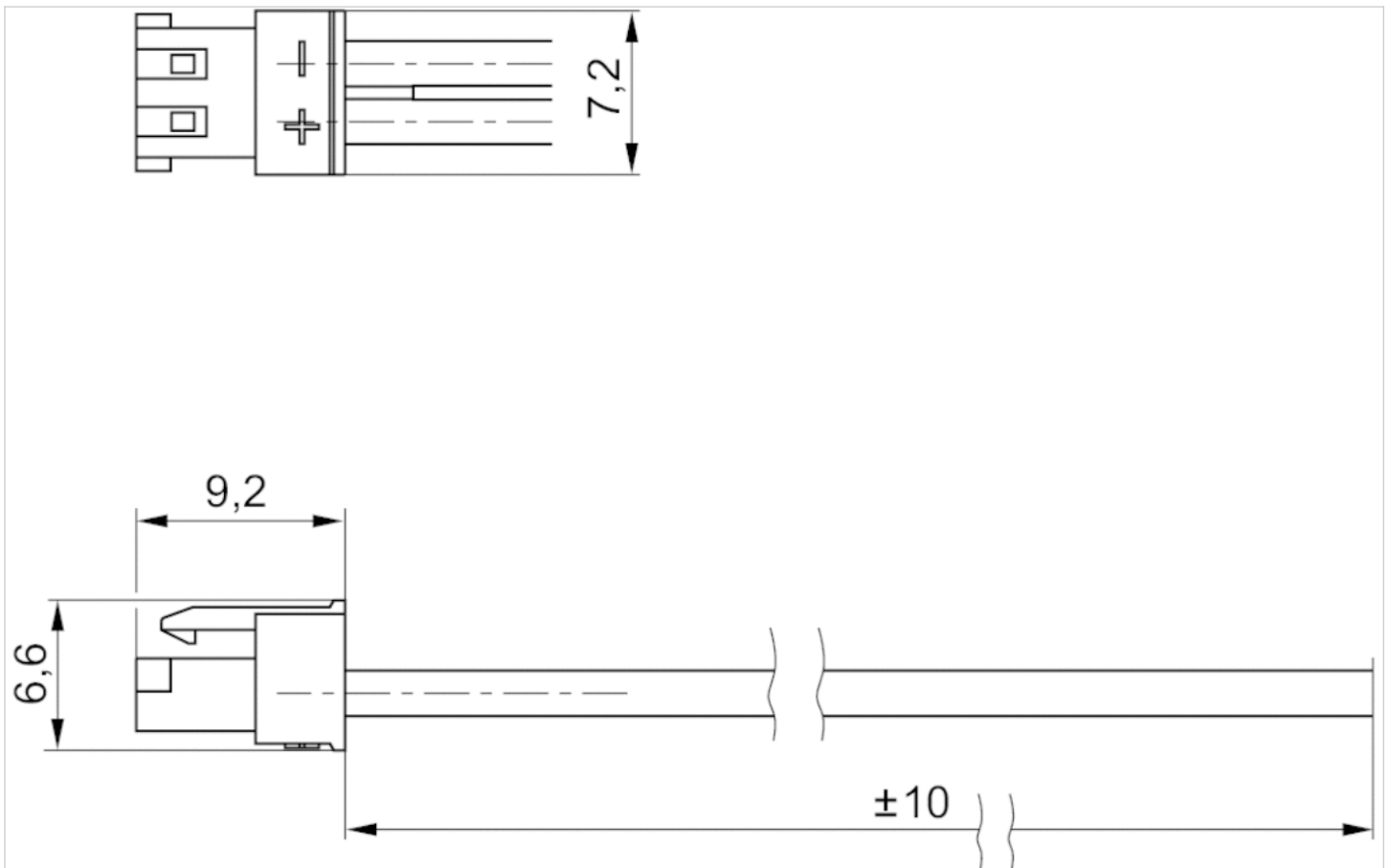

Dimensions, Fig. 2

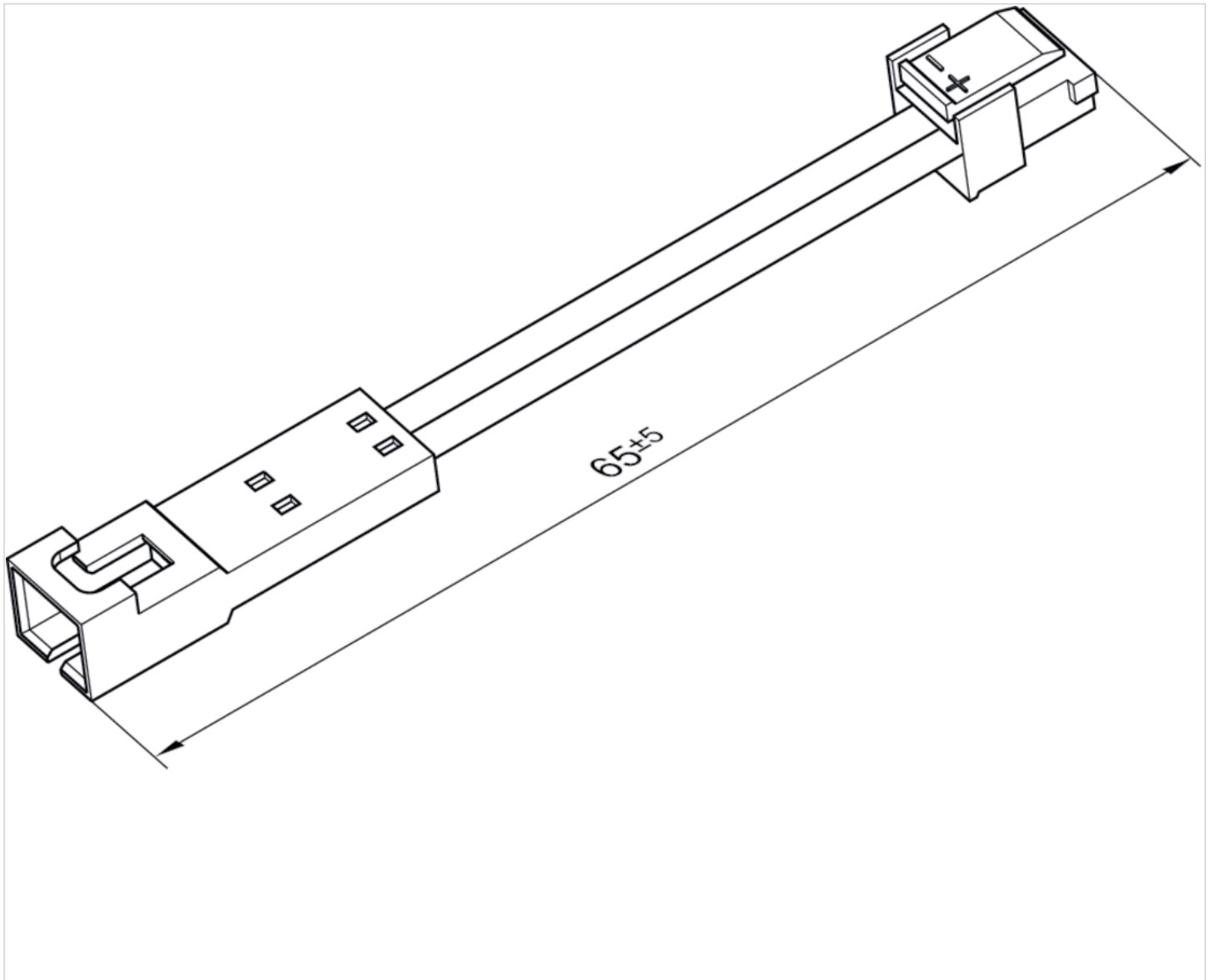

Efficient pneumatic solutions, our program: cylinders and drives, valves and valve systems, air supply management



Visit us: Emerson.com/Aventics

Your local contact: Emerson.com/contactus



Emerson.com



[Facebook.com/EmersonAutomationSolutions](https://www.facebook.com/EmersonAutomationSolutions)



[LinkedIn.com/company/Emerson-Automation-Solutions](https://www.linkedin.com/company/Emerson-Automation-Solutions)



[Twitter.com/EMR_Automation](https://twitter.com/EMR_Automation)

An example configuration is depicted on the title page. The delivered product may thus vary from that in the illustration. Subject to change. This Document, as well as the data, specifications and other information set forth in it, are the exclusive property of AVENTICS GmbH. It may not be reproduced or given to third parties without its consent. Only use the AVENTICS products shown in industrial applications. Read the product documentation completely and carefully before using the product. Observe the applicable regulations and laws of the respective country. When integrating the product into applications, note the system manufacturer's specifications for safe use of the product. The data specified only serve to describe the product. No statements concerning a certain condition or suitability for a certain application can be derived from our information. The information given does not release the user from the obligation of own judgment and verification. It must be remembered that the products are subject to a natural process of wear and aging.

The Emerson logo is a trademark and service mark of Emerson Electric Co. Brand logotype are registered trademarks of one of the Emerson family of companies. All other marks are the property of their respective owners. © 2017 Emerson Electric Co. All rights reserved.
2019-03



CONSIDER IT SOLVED™